

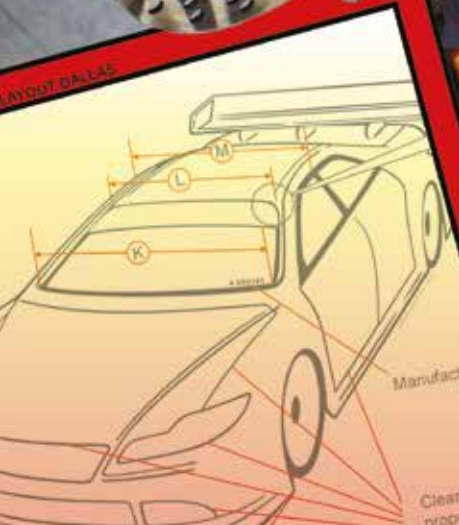

HANDBOOK 2017

EUROPEAN FEDERATION OF RADIO OPERATED MODEL AUTOMOBILES



Manufacture

Clearly visible proportions are



APPENDIX 2

1/8th SCALE OFF ROAD CARS

1. ALLOCATIONS FOR EUROPEAN CHAMPIONSHIPS

- 1.1. The number of drivers and the National Allocations for the European Championships will be decided upon at the EFRA AGM annually. According to the following table.

	GP	EC B	ECA/ ECA+	Open EC 40+	Euro- Indoors
Days	Fri./Sun.	Fri./Sun.	Tue./Sat.	Fri./Sun.	Fri./Sun
Nin/Max No of drivers	120/144 max	120/144 max	150/180	120/144	120/144 max
The Venue (Track, Rostrum, pits space, commodities, etc...) must be sufficient for all participants.					
Recommended Date	2nd weekend of the month	2nd weekend June	2nd weekend July	2nd weekend Sept- ember	2nd week from Nov- ember- February
Compulsory License	EFRA or National	EFRA	EFRA	EFRA	EFRA
Allocation	NO	YES	YES	NO	
Restrictions	NO	See 1.5	NO	NO	NO

- 1.2. EC A+ with more than 150 drivers can only be allocated to federations that have already organized a successful EC B or EC A in the precedent years.
The National Federation must confirm the capacity of the organizer for an event with more than 150 drivers. In order to ensure the appropriate rotation in the venues of ECA & ECB, when considering applications for each kind of event, the venues who had not allocated one of those in the preceding 3 years will have preference.
- 1.3. For allocation and re-allocation procedures see 3.6. and 6.2.
- 1.4. If a driver has not registered by midday on the first day of the event, then his place will be re-allocated unless that driver has contacted the organizer to explain his reason for not registering
- 1.5. A 4WD European Championship for B Class drivers may be organized each year. Entries will not be allowed for drivers who have already won that event or who have ranked in the first fifty (50) places of any of the preceding two (2) 1/8th Off Road EC A Championships and to any driver who has ever taken part in an EFRA European Championship A main final in any class of racing. To be run if possible the 2nd weekend of June.
- 1.6. Allocations lists with reallocations for EC A & B to be published on EFRA website: 5 weeks before the first day of the event.
- 1.7. a). An Open 40+ EC may be organized each year, Preferably Mid September.
A designated tyre system may be used for this event following a decision made at the previous section meeting.
b). An Indoor EC may be organized each year, preferably from 2nd weekend of November to February.
c). The Indoor EC may also include Electric 1/8th models.
The Main final to be 3 races of 10 minutes duration.

- 1.8 All European Championship organizers must inform EFRA before 31 December the year before about the best tyre combinations for their track.
- 2. RACING FORMAT EUROPEAN CHAMPIONSHIPS AND G.P.**
- 2.1 All Events, formats and timetables should be adapted to the real number of entrants and facilities. The 3 days events, i.e. the GPs, the European Championship for B class drivers and the Open Entry EC Events will have the same format as specified in the following rules adapted to a 3 day event with only four (4) attempts at qualification, only two (2) to count, weather permitting. Entries will be limited to 120 drivers, special allowance can be given by the EFRA AGM Section Meeting up to a maximum figure of 144 drivers, and reseeding of the heats will only be done in case of clear necessity on the criteria of the R.D. and Referee. Order of the rounds will be always the same, from 1 to 12. With the fastest drivers into the last groups. At the GP held at the event intended to host the European Championships in the previous year and in the same year i.e. the warm up event, the full race program should be used and tested including the reseeding of heats after practice.
- 2.2 **QUALIFICATION HEATS:**
- a) If the host country wants to, and the facilities can accommodate 180 drivers, qualifying rounds can be up to 15 cars. This decision will be made by the Section Chairman, the Referee and the Race Director
 - b) Each driver should be entitled to a maximum of 5 attempts at qualification, weather permitting.
 - c) Starting for qualifying will be with 'Flying start'. The track will be opened normally with a 3 minute warning to the start, this will be announced through the sound system, you will also get the time "2 minutes to start", "1 minute to start", "30 seconds to start" and "10 seconds to start". Deliberate stops waiting for the signal at the track and cutting the track to find a better position in it are infringements to be penalized unless otherwise authorized by common decision of the Race Director and the Referees communicated at the Team Manager Meeting.
The announcement: "Clock is running" will indicate that the heat has started. All qualifying runs and finals are ran by "time plus next lap" system. Qualifying heats are of 5 minutes duration. The choice of general rule 9.3, a or b, will be done before the official start of the event by the Race Director and clearly stated at the Team Managers meeting.
 - d) All drivers will be entitled to a sub-final.
 - e) Heats will be run in the following sequence for the 5 qualifying rounds:
Round 1: 1, 2, 3, 4, 5, 6, 7, 8, 9, 10, 11, 12, 13, 14, 15
Round 2: 4, 5, 6, 7, 8, 9, 10, 11, 12, 13, 14, 15, 1, 2, 3
Round 3: 7, 8, 9, 10, 11, 12, 13, 14, 15, 1, 2, 3, 4, 5, 6
Round 4: 10, 11, 12, 13, 14, 15, 1, 2, 3, 4, 5, 6, 7, 8, 9
Round 5: 13, 14, 15, 1, 2, 3, 4, 5, 6, 7, 8, 9, 10, 11, 12.
- 2.3. **TIMED PRACTICE SYSTEM**
- a) The practice for drivers will only be run in the way of rounds in heat order. On Tuesday there will be 4 rounds of practice, 1st, 2nd & 3rd of 5 minutes duration and a 4th one of 9 minutes track time. On Wednesday before the start of the 2 rounds of Controlled Practice there will be a "track shake-down round" early in the morning, only the Wednesday controlled practice rounds will count for reseeding. These rounds will be of 10 minutes duration with the last 5 minutes timed. Announced as rule 2.2. if needed. Best 3 consecutive laps inside the whole 10 minutes or the complete

last 5 minutes may be used for reseeding purposes. The selection of the reseeding system is done by the race director and must be clearly advised before the start of practice. Results of the timed practices will be published (laps and times). Points will be awarded according to the result selected for reseeding in each round. The best single point result scored out of these two rounds will be used to sort drivers by performance and to reseed them before the real qualifying rounds. In event of a tie second point result will be taken into account to solve the tie.

- b) Reseeding: After timed practice and subject to frequencies and common sense the top 36 drivers will be placed in the first 3 heats with equal number of each country up to a maximum of 5 drivers in each heat. The first 3 drivers take 1st place in the first 3 heats, next 3 in second place at each heat and so on. Use this system to include 144/180 drivers and avoid small teams being placed in the same heat. The sort out problems round after reseeding can be done alternatively wednesday afternoon after the opening ceremony or early thursday morning.

2.4. QUALIFYING SYSTEM

In each round drivers will score points based on laps and times achieved. For all rounds the maximum number of points given to the fastest driver will be equal to the number of drivers participating to the EC + 5 (five). 2nd fastest will score the maximum minus 2 (two) points. 3rd fastest will score the maximum minus 3 (three) points. Down to the last position one by one. If a driver has not completed a lap, no points will be awarded in that round. In every round in the event of a tie the points will be equally awarded to each driver and the first driver not tying will get one point less. In the case of two or more drivers having the same points score the next best score determines position. If still unable to resolve with the next best rounds then driver with fastest laps and times will determine position.

Out of 5 completed rounds 3 to count

Out of 3 and 4 completed rounds 2 to count

Out of 1 and 2 completed rounds 1 to count

2.5. FINALS

- a) All finals can be of 12 cars with 4 cars progressing to next final, and 6 cars from each semi final proceeding to Main A Final, together with a 13th car, that spot will be decided on a race of 15 minutes duration, after the first exhibition final.

“A” series sub-finals will be composed of Odd places drivers following qualification. “B” series sub-finals will be composed of Even placed drivers after qualification. Every qualifying driver must progress to the main final in accordance with the accompanying Christmas tree. All sub-finals up to and including 1/128th A and B will be of 15 minutes duration. Then from 1/64th to quarter finals 20 minutes, Semi-final A and B 20/30 minutes, the final should be 45/ 60 minutes. The top 3 (three) / 4 (four) from each up to the quarter finals progressing to the next sub-final and the first 5 (five) / 6 (six) from each semi-final progressing to the Main Final. After the finish of the quarter finals each semi finalist (“A” and “B”) is entitled to 10 minutes practice time with numbers and appropriate radio frequencies (See attached Christmas tree). TQ driver after qualifying will have the right to practice in both semifinals. First semifinal to start no sooner than 15 minutes after the end of practices. If the first subfinal is 1/1024 or less then all subfinals will be 20 minutes duration. There will be an exhibition final

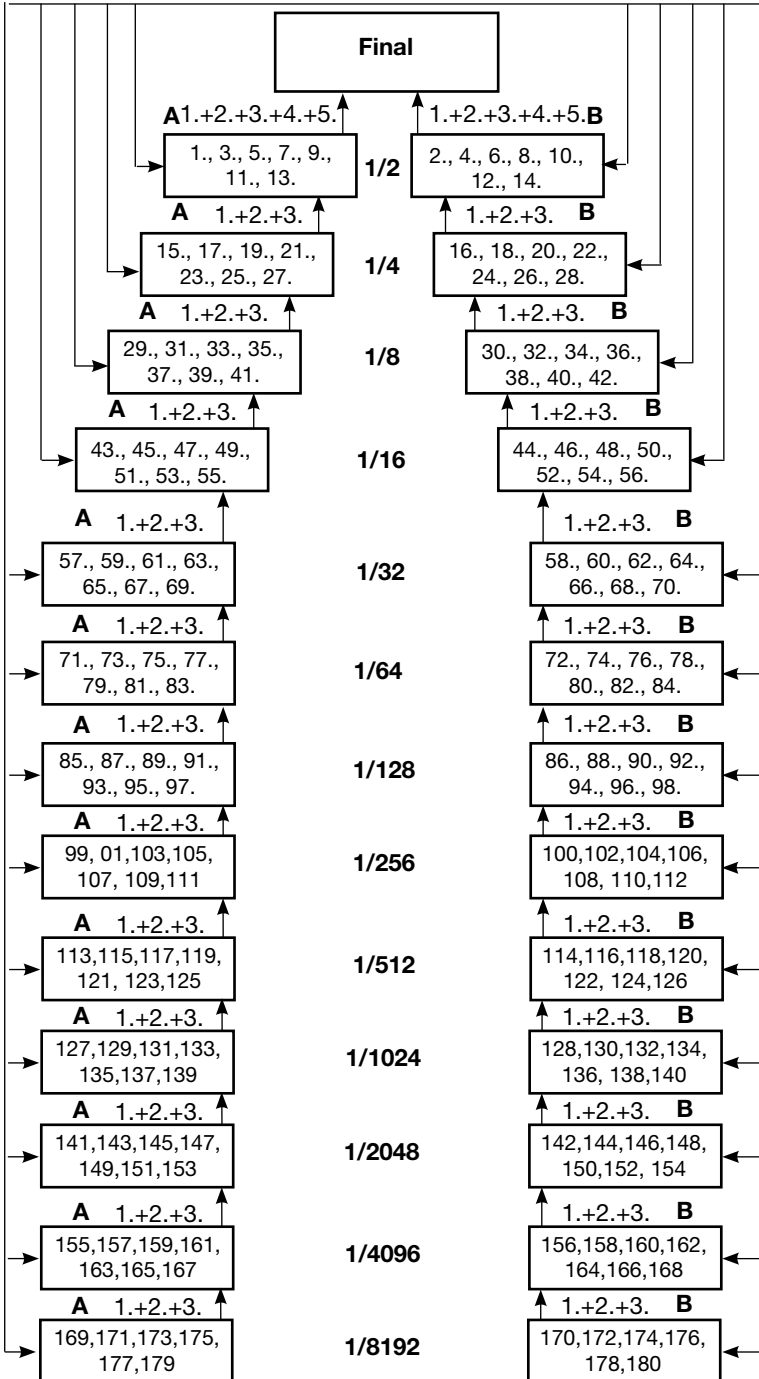

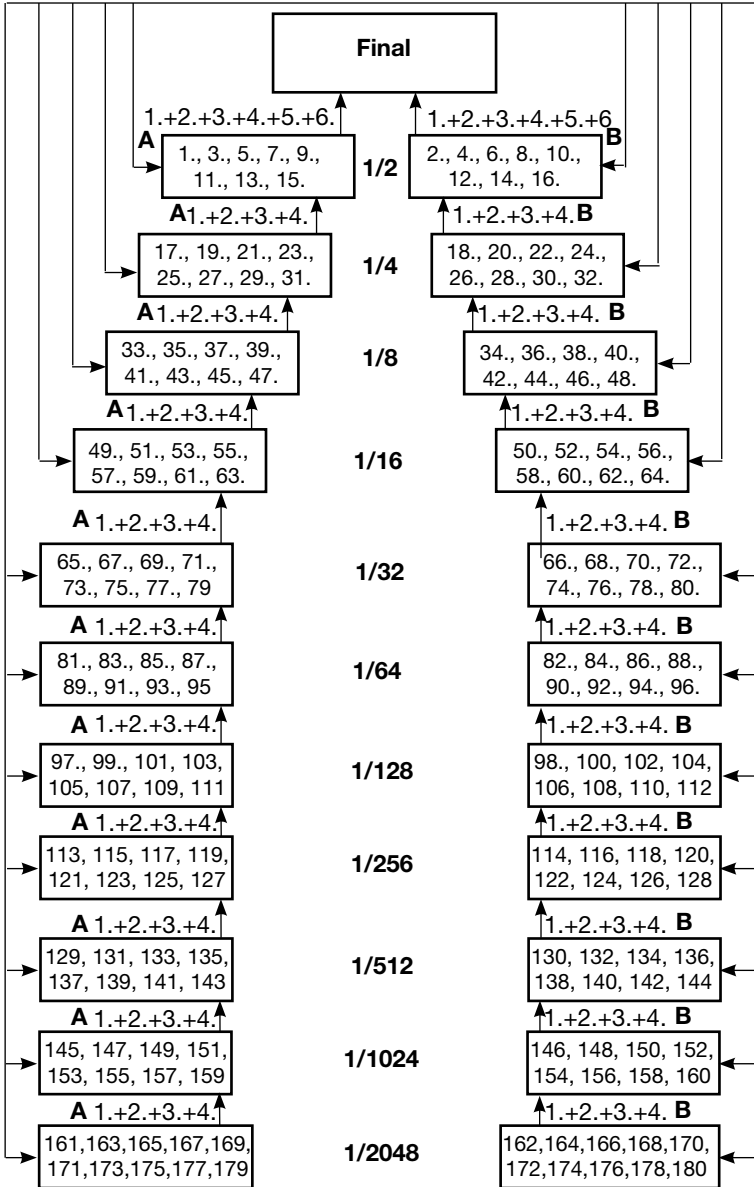

for +40 drivers after the 2 semi finals and before the main final, length of that final will be 20 minutes. Drivers will qualify for that final according to their result achieved at qualification rounds, top 10/12 will have the right to compete at this final except those who have reached the semi finals.

There will be an exhibition final for under 17 drivers after the 40+ final before the main final, length of the final will be 20 minutes. Under 17 final is for all drivers who are 17 or younger on the year of competition. Drivers will qualify for that final according to their results achieved in the qualification rounds, top 10/12 will have the right to compete in this final. In the case of no under 17 driver in the main final, then the winner of the under 17 final will be the European Junior Champion.

b) Special rules for EUROINDOOR Championship:

Format of Euro B with the following modifications:

All subfinals will be of 15 minutes duration.

Main final on 30 minutes duration

there will be no +40 final.

TQ driver will classify directly for the main final. TQ driver will practice in both practise of semifinals, A & B.

Bump-up for the main final will be 5+5 (4+4 in event of a 10 drivers final), the remaining spot will be decided on a race of 10 minutes duration, after 15 minutes preparation time.

2.6. TIMETABLE

The timetable for E.C. shall be as follows: The Race Organiser should schedule all events for each day to be completed and the track closed by 18:30.

TUESDAY	A.M. Registration & Technical Inspection + 1st, 2nd & 3rd rounds Timed Practice (5 minutes) P.M. 4th round Timed Practice (9 minutes)
WEDNESDAY	Early in the morning shake-down round + from 10:00 2 rounds Controlled Practice (10 minutes) P.M. OPENING CEREMONY Reseeding of drivers from practice times. Top 36 in 1st 3 heats 37 - 72 in next 3 heats 73 - 108 in next 3 heats 109 - 144 in next 3 heats 145 - 180 in last 3 heats 1 round of timed practice to sort out problems
THURSDAY	3 rounds qualifying
FRIDAY	A.M. 2 rounds qualifying P.M. 1/8192 Finals A & B (A is run first) 1/4096 Finals A & B 1/2048 Finals A & B 1/1024 Finals A & B 1/512 Finals A & B 1/256 Finals A & B 1/128 Finals A & B
SATURDAY	64 Finals through to "A" Final Final to commence 15.30

Official Prize Giving/Reception/Banquet to be held after Main Final at a time to be announced by the Organisers. Banquet Tickets to be sold in advance if such existing.

3. TRACK

Minimum Width: 4 metres
Minimum Length: 250 metres

3.1 SURFACE

Artificial surfaces should be of the same type used for road construction. They must not be potentially dangerous or pollutant.

Within the total length of the track 50 percent (50%) minimum must be from natural soil.

Any section made from artificial surface must not be longer than ten (10) metres. A natural soil section must always separate two (2) artificial surface sections.

At place of the lap counting antenna, there must not be any metallic structure. Deterioration of the natural soil area must not uncover obstacles in the transit area between natural soil and artificial surface (overlapping slope must be smooth and of sufficient length).

The track must be suitably drained.

3.2 JUMPS AND OBSTACLES

Their sizes must be in relation with the scale of the car.

3.3 SAFETY

Safety for everybody must be the most important aspect when designing a track and at every moment while race is on progress. All non authorised people will have to leave the track area when the call 1 minute to start is given. Press and media will be informed of this rule by the organizer when obtaining their press pass.

3.4 MAINTENANCE

The track surface may only be repaired at the following moments:

Any time at the end of any practice round during practice days, and after the practice and before the qualifying rounds.

At the end of day one of qualifying.

At the end of qualifying and/or at the end of the second day of qualifying.

The Race Director can authorise repairs, if he considers the track to be unsafe at any time with the agreement of the referees.

3.5 OTHER TRACK SPECIFICATIONS

3.5.1 A pit lane must be provided that has a convenient and safe entrance and exit to and from the racing surface. It must be separated from the racing surface by a secure barrier. There must be a second barrier of at least the same specifications of the outer barrier between the pit lane and the working pit areas. The design of the pit lane access and exit must be done to prevent high speed racing at the pit-lane.

3.5.2 All refuelling, repairing, or servicing of cars must be accomplished with the vehicle fully behind the barrier between the pit lane and the working pit area, and not in or over the pit lane. Cars may be placed on top of the pit wall for servicing provided the wall has been designed so that the car is secure and stable.

4. RACE PROCEDURES

Race procedures shall be as follows with the addition of the non contradictory rules of section 4 of Appendix 1 up to 4.9, basically part of 4.1 (mechanics position), rule 4.3 , rule 4.7.7 to 4.7.11 and rule 4.9 . It is forbidden to cut the track during the warm-up minutes unless otherwise advised and it is forbidden to overtake while the formation lap is on progress (if existing). It is not allowed to the mechanics go to or to come back from the starting grid when count down has started, penalty for that is a 10 seconds stop & go.

In case a race cannot be completed for whatever reason the final ranking will be made as follow:

Ranking of sub finals will be used up to the level where the last pair of sub finals A & B have been run.

Above that level, for the remaining drivers, the qualification ranking will be used.

	A	B	
Final	Not Raced	Not Raced	↑ Ranking Qualification
....	Not Raced	Not Raced	
Sub Final N	Not Raced	Raced and void	
Sub Final N-1	Raced	Raced	↑ Ranking Sub finals
....	Raced	Raced	
Sub Final N-x	Raced	Raced	

Parc Ferme:

All cars of the the first semi-final will be impounded in parc ferme during the later semi-final. All cars of both semi-finals will be released at the same time.

Delayed Start:

As long as the starter has not called the cars to the start line (30 seconds to the start call), every participant of the semi-finals and the final may request a delay of ten (10) minutes for repairs on his car. The delay will be granted only once for each semi final and main final. The track shall be closed to all cars during the delay period. The driver that asked for the delay has to start last from the startgrid (11th or 13th position).

- 4.1 The track for a European Championship MUST be either new or repaired new before the day it is open for practice. Whether the track is a new track made for the event or an existing track it can not be open to drivers for practice before the day the official practice is scheduled. The National Federation and the organising Club must forbid any use of this track 4 weeks before the event.
- 4.2 For Electric 1/8th all finals will use a "Le Mans" or "F1" type grid start, with a minimum of 3 meter alternating intervals with two rows of cars. Cars must be placed forward facing to their markerline or start box.
If F1 start is used, then the Top Qualifier shall choose if the first car on the grid shall start on either left or right side and shall be used for all finals.

5. TECHNICAL SPECIFICATIONS

4 WD 1:8 OFF ROAD CARS

5.1. GENERAL DIMENSIONS

- a) Overall length 550 mm maximum
- b) Overall width 310 mm maximum at any point of suspension travel.
- c) Wheelbase 270 - 330 mm.
- d) Overall height measured from the ground including rollbar with full suspension compression 250 mm. maximum (this measurement does not include the receiver aerial).
- e) Minimum weight is 3.200 kg for 4 WD.
- f) No other function than steering and throttle/brake are allowed to be operated with the Radio Control by the driver. Any other electronic system placed in the car different than the personal transponder and a possible switch on-off is not allowed.

g)

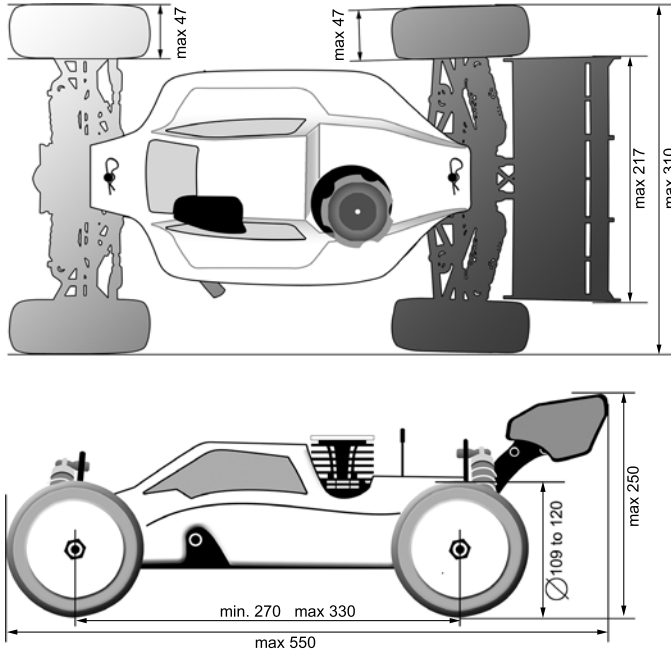

Wheel overall diameter must be between 109 and 120 mm. Wheel overall width 47 mm maximum.

- h) Measuring equipment for width, length and height should be constructed preferably from metal or alternatively high quality board. The materials will be of suitable thickness to eliminate any distortion.
- i) The front of the vehicle chassis must be equipped with a plastic bumper (no metal at all) in such a manner that it will minimise damage in the case of it entering into contact with other participants, marshals or any person. The bumper must be made from flexible material (plastic) with all corners and sharp edges rounded off. If a rear bumper is used it must follow the same principles.

5.2. ENGINES & TANK

- a) Internal combustion engines with maximum capacity 3.5 ccm.
- b) Fuel tank capacity: 125 ccm including all piping tubes and filter up to the carburettor.
The tank shall be measured using the official EFRA measuring cylinder or in the event of damage to the official cylinder, a cylinder to DIN standard.
- c) The capacity of the fuel tank must not be adjusted by insertion of any loose object
- d) Any tank found illegal (>125 ml) after a heat or final shall be removed from the car and inspected for a second time after an initial "cool down period" of 15 minutes. This period of 15 minutes is only necessary in case the track air temperature is above 20° C.

5.3. SILENCER

5.3.1 Each motor must be equipped with an exhaust system and an inlet silencer to reduce the amount of noise generated by the car.

The maximum noise level for a muffler with INS box is 83 dB's, measured at ten (10) metres distance and one (1) metre high for a single car.

EFRA's definition of a noise level is always final.

Only EFRA homologated mufflers published for the season are allowed on EFRA sanctioned events. The EFRA homologation number must be engraved on the sidewall of the muffler.

5.3.3 EFRA may noise test any car at any time during the event. EFRA noise testing equipment will make all tests regarding noise levels. EFRA's definition of noise is final. From 2017 when the noise trap is in use penalties may be given at qualifying (loss of the drivers best result) or finals (minus 1 lap on the final).

5.4. TYRES

All tyres must be black with the exception of side wall lettering. The application of any additives within the event perimeter is strictly forbidden. The penalty for that is immediate disqualification.

No spikes, tubes or additional items intended to increase traction may be either glued to the outside of tyres or passed through tyres from the inside. All EFRA ECs on 3 days scheme can be run under a designated wheel (insert, tyre and wheel to be the same for all drivers) system, no use of tyre additives are allowed at all.

5.5. WINGS

The rear wing with a maximum overall size 217 mm length and a chord of no more than 85 mm may be fitted.

-The multiplane wings are authorized

-The width of 85 mm is measured between the lower leading edge and the higher trailing edge.

The side dams of the wing must have a maximum horizontal width of 100 mm and a maximum height of 70 mm.(irrespective of the orientation)

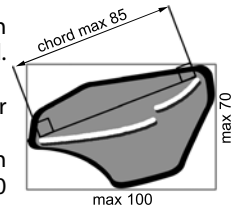

- The single of multiplane wing must be registered inside the contour of the side dams. - The wing and the side dams must be made out of flexible material with angles rounded.

5.6. APPEARANCE

a) Cars shall be a reasonable representation of the style of car used for offroad, desert or trial racing.

b) Full bodysHELLs of saloon style are permitted but may only be trimmed to expose a maximum of 50% of the tyres at full suspension depression. If such bodysHELLs are fitted, provision for trimming shall be as in Section 5.6d.

c) Where a roll-cage is fitted, an open wheel style bodysHELL must be fitted underneath the cage so designed as to enclose R/C equipment and fuel tank with sufficient front and side areas to allow clear display of racing numbers.

d) Openings may be cut in the shell for the antenna and the pipe ends and to allow access to fuel filler, switch, and engine adjustments, and a maximum of a third of the wind screen to assist in cooling the engine if not already opened by the fuel tank access.

e) The car bodysHELL holding the car identification number must be fitted, if it becomes loose or detached it must be fixed in the immediate next lap.

Clearance around such items to be kept to a minimum.

“Acceptance of a saloon bodyshell by another EFRA Section shall be deemed to simply approval by the Off-Road Section for racing purposes.”

- 5.7. Fuel may only contain methanol (methyl alcohol) CAS number 67-56-1), lubricating oil, a small content of anti-corrosion chemicals and maximum 25% of nitro methane (Cas number 75-52-5) in volume. The specific gravity of the mixture may not be heavier than 0.91 grams/cc at 20°C and standard atmospheric pressure. For quick testing a Nitromax 25 can be used , but in case of failure with the Nitromax an official density meter must be used to control the specific gravity of the fuel including the temperature recorded during the test. A specific table will be produced to report the density (gr/cc) based on the temperature (from 0 to 50°C) The tolerance on the measurement will be +/- 0,5% based on the data reported in density table. Any violation with fuel which means any proof of the use of other additives as mentioned will means 5 years of disqualification from any EFRA and IFMAR event.

5.8 Electric 1/8th Technical

5.8.1 MOTORS:

Can : Maximum overall length is 77.00 mm measured from the mounting face of the motor to the furthest most point of the end bell, not including solder tabs, lead wires or original manufacturer's logo or name. Motor mounting holes must be on 1.00- inch (25.40mm) centers.

Stator: Motor stator maximum outside diameter is 39 mm.

Rotor: External shaft diameter shall be 5mm. It may only be either a 2 pole or a 4 pole design with a maximum 12-slot stator.

5.8.2 BATTERY CELLS : 14.8v lithium battery maximum

- 11.1v 3s Lipo
- 14.8v 4s Lipo
- If two 2s 7.4v Li-Poly packs are used, they must be the same brand and part #.

5.8.3 TRANSMISSION AND DRIVE:

- Single speed transmissions only
- 4WD

5.8.4 BODYSHELLS

Body Style: The body has to be able to carry the EFRA Numbers at the front and both sides as high as possible. The body has to have a real car shape.

Body shell holes/vents: Only 9 holes with a maximum diameter of 10 mm and one hole for the antenna are allowed. Windows are not allowed to be removed. All Gears must be covered from above.

5.8.5 SPECIAL ELECTRIC SAFETY RULES

At Technical inspection it will be checked that no battery shows any deformity or manipulation. Batteries have to be protected by the chassis or body.

Maximum voltage before any run 16:80 v before the start of the run.

6. NATIONS CUP

At every European Championship A&B EFRA will hold a Nations Cup, with drivers competing as a team representing their countries. Before the start of the official qualifying rounds each Team Manager will provide the Race Director with a maximum of four (4) names of drivers which will represent their country at this Nations Cup. Out of this four drivers the best result in points according to their final position achieved of the best three (3) of them will be added together and give the result of their National Team.

7. TROPHIES

The organizer must furnish, at least, the following trophies for the prize giving ceremony:

- Appropriate trophy for positions 1-2-3 at the 3 standard classifications, Absolute final, under 17 final and over 40 final.
- Trophy for positions 4-10/12 of the Absolute final classification.
- TQ Trophy, to be presented after classification is completed and returned for the final ceremony.
- 3 pairs of plates for the Mechanics of positions 1-2-3 of the Absolute final classification
- 3 set of 5 plates to the Nations Cup positions 1-2-3.
- 1 Trophy for the manufacturer of the winner car at the EFRA ECA
- 1 Trophy for the manufacturer of the winner engine at the EFRA ECA
- 1 Trophy for the manufacturer of the winner tires at the EFRA ECA

The Trophy of the Nations cup will be kept in deposit by the Winner national association and returned before the start of the next European Championship.