

**EUROPEAN FEDERATION OF  
RADIO OPERATED  
MODEL**  
*Automobiles*



**Appendix 3  
HANDBOOK  
2010**

## APPENDIX 3 ELECTRIC CARS

### A GENERAL

#### 1. RACETRACK SPECIFICATIONS for electric classes

- 1.1.1 For EFRA-sanctioned events, where non-permanent tracks are used, the track plans have to be submitted to the Section Chairman for approval.
- 1.1.2 Track-design must include both right and left-hand turns and one or more straights.
- 1.1.3 Minimum track length: 120 meters.
- 1.1.4 Outside barriers must provide a positive means of stopping a car that misses a corner or runs out of control.
- 1.1.5 Track marking equipment must be such a shape and size to prevent the entrapment of a car or the drivers view becoming obscured. 'Horizontally laid triangular column' shaped barriers and 'Bot dots' are not to be used.
- 1.1.6 Farthest point of the track must not be more than 50 meters away from driver's rostrum.
- 1.1.7 Time-keeping: preferable on a slow part of the track to enable accurate counting.
- 1.1.8 Marshall positions based on car numbers must be equally spread around the track. It should be clear which part of the track the specified position is responsible for.
- 1.1.9 A 220-volt electrical supply must be available at EC meetings with one outlet for every four drivers in close proximity to their pitting area. All safety precautions must be observed.
- 1.1.10 For the EFRA staggered start system one start line must be marked across the track, preferably close to the time-keeping's pick-up loop position (otherwise two).
- 1.1.11 All finals will use a "F1" type grid start with a minimum of 2 meter alternating intervals with two rows of cars. Cars must be placed forward facing to their markerline or startbox.
- 1.1.12 Wherever possible the start line(s) must be accessible without crossing any other part of the track.
- 1.1.13 The start line will be white or yellow coloured, have a minimum width of 5cm and shall cover the total width of the track and will also be marked on the barriers. There shall be marked boxes for the final F1 grid.
- 1.1.14 Top Qualifying driver may choose his starting position on the grid either left or right, this then to be the configuration for all remaining finals.
- 1.1.15 Marshall intervention must be minimised by using smooth obstacles such as dots or cones, of appropriated heights.
- 1.2. Specific track requirements for 1/12 & 1/10 Touring class tracks
  - 1.2.1 Indoor track surface must be needle carpet with smooth joints properly attached to the floor.
  - 1.2.2 For onroad racing, only smooth surfaces will be allowed.
  - 1.2.3 Indoor Limits: minimum track width 2 meters between the marking lines. At the start line the track must be at least 3 meters in width as far as the first turn. Marking lines must be either white or yellow, minimum width of 2.5 cm, and must be at least 20 cm away from the edge of the racing surface or track barrier.
  - 1.2.4 The track surface for 1:10 Electric Saloon Cars can be both asphalt or needle carpet.
  - 1.2.5 The track surface for 1/12th electric sports cars must be indoors on needle carpet.
- 1.3. Specific track requirements for 1/10 Off Road class tracks
  - 1.3.1 Width: 3 metres minimum.

- 1.3.2 The spirit of scaled down off Road racing must be adhered to. (Modified On-Road tracks are not considered suitable).
- 1.4 Requirements for time-keeping equipment
- 1.4.1 The main timing PC must automatically announce the following in clear English:
  - 2 minutes to the start of the race
  - 30 Seconds to the start of the race (& start order for staggered starts at this point)
  - 10 second countdown and start 'Sound' for line starts (i.e. finals)
  - 10 second countdown and call the cars off the line in case of staggered starts
  - Time calls and race order every 2 minutes
  - Cars finished & race over

**2. MOTORS FOR ELECTRIC SCALE CARS:**

All EC and GP events will clearly state which class of motors to be used.

**2.1 REBUILDABLE 19T SPEC. MOTORS**

The Can.

1. Can diameter, before any surface finish is applied, is 36.02 mm max.  
The overall length of the assembled motor is 53.0 mm max., measured from the mounting face of the motor to the furthest point of the end bell, not including solder, tabs or lead wires. Only ceramic magnets can be used (Cobalt and rare earth magnets are not allowed). There is no limit on the number of magnets used. Current is supplied to the armature commutator by 2 brushes.
2. The can will be stamped with the name of manufacturer and '19 Spec'.
3. Ball-raced bearings are allowed.
4. The can will incorporate a slot to locate the end bell at a designated timing advance of 24 degrees maximum.  
The can will have two pairs of mounting holes. The pairs of mounting holes can be positioned by either of the following :-
  - a) Both pairs within the space between the magnets. The line through the mid-point between each pair of mounting holes must pass through the centre of the can and is determined as being zero degrees.
  - b) One pair within the space between the magnets. The line through the centre of these holes must pass through the centre of the can and is determined as being zero degrees. The second pair will be at 90 degrees to the zero degree line.

The zero degree line will be marked on one side of the can to indicate zero degrees.

The centre of each magnet (or assembly of magnets) on each side of the can will be at 90 degrees to the 0 degree centre-line, with a tolerance of +/- 2 degrees.

5. Magnets must be permanently glued to the motor can and may not be removed. No magnet shims are allowed (e.g. an extra shim that could be added on the end of the magnet or between the tips to change performance). Flux collector/timing rings are allowed as long as their only purpose is to secure the end bell to the motor can. Such rings may not extend between the magnet tips.
6. The motor can must have inspection holes/slots between magnet tips so that the armature may be viewed for inspection. These holes/slots may be no closer than 5.00mm from either the open end or mounting face of the motor can. The view through the inspection holes/slots must not be obstructed by anything covering the holes/slots (e.g. motor label).

The End-Bell.

7. Ball-raced bearings are allowed.
8. The end bell will incorporate a 'tab', which when assembled to the slot in the can must result in a designated timing advance of 24 degrees maximum. When the end-bell assembly is secured to the can, the brush hoods will be aligned at 90 degrees to the can zero line, plus the allowed timing of 24 degrees maximum.  
Brush hoods/tubes will be assembled at 180 degrees apart. The centre of the brush hood/tube will be in-line with the centre of the armature.
9. End bells must be marked with the manufacturer's name.

The Armature.

10. The shaft diameter is 3.175 mm.  
The rotor to have three poles with windings. Length of stack is to be 21.00mm min. to 22.80mm max (both dimensions measured with epoxy/hysol insulation coating removed). The thickness of the 'stack' laminations is 0.35mm +/-0.05mm. The width of the stack web will be 3.50mm minimum with epoxy/hysol insulation removed.  
The armature has to be permanently marked (or tagged) by the manufacturer, showing the number of windings and the name of the manufacturer.
11. The commutator slots must be aligned with the centre of the individual poles, with a tolerance of +/- 2 degrees.
12. The armature will be wound using a single wind of round 19 AWG (American wire Gauge) copper wire giving 19 Turns. It is not mandatory to use the 'Mabuchi' cross wrap technique for winding the armature. There is no plus tolerance on the wire diameter. Armatures must be machine wound, 'hand winding' is not permitted. It is not mandatory to use a locking device between the commutator and the armature stack.
13. Tabs on the armature's commutator may only be "compression welded". No after-market welding, soldering or silver brazing will be permitted.
14. Epoxy balancing of armatures will not be permitted.
15. Only full stack armatures with no cut-outs are allowed. No split, skewed, tri-rotors etc. are allowed. Longitudinal slots/grooves parallel to the armature shaft in the pole crowns are not allowed on any armature introduced after 01.01.02. The crowns of each pole must be symmetrical in cross section, with a constant crown radius. Steps in the crown are not allowed.
16. No modifications to the OEM armature stack may be made, other than the drilling/grinding of balancing holes. Modifications to the OEM designs, including (but not limited to) excessive drill holes, milling or turning to lighten or enhance the performance of the armature are not allowed.
17. The armature shaft does not have to extend beyond the end bell, but any extension has to have a reduced diameter to form a parallel step.

Timing.

18. The overall timing of the assembled motor is determined by the allowed tolerances of the individual assemblies, (I.e. Magnet position, Commutator position, Location of End-bell to Can).

General.

19. No modifications to the OEM construction/design of the motor can, end bell, or armature will be permitted. (e.g. adding or removing material from the armature stack, changing the dimensions or orientation of brushes or brush hoods, relocating spring posts).

20. The armature, motor can, and end bell must all be from the same OEM and can contain only components from the same model. No hybrid motors or mixing of parts from different models will be permitted.
21. All motors used in EFRA sanctioned events must have their original motor builders label(s) substantially intact to be eligible.  
Organiser may offer one "handout" motor to all competitors entered in the "Spec Car Motor" class. Where "handout" motors are used, the competitor may not make any changes to magnets or springs during the event.  
Costs of the handout motor (without profit to the organiser) may be charged to the competitor

2.2 MODIFIED BRUSHED MOTORS

Specifications '05' sized displacements:

Can:

Can diameter to be a maximum of 36.02 mm. Overall length to be a maximum of 53 mm measured from the mounting face of the motor to the furthest point not including solder, tabs or lead wires.

Current is supplied to the armature by 2 brushes.

Only Ceramic magnets are permitted. (Cobalt and rear earth magnets are not allowed)

Armature:

Shaft diameter is 3.175mm (0.125inches), production tolerances are allowed. The rotor shall have three poles with windings. Stack length 21.00mm minimum, 22.80mm maximum (both dimensions to be measured with Epoxy/Hysol insulation removed). No split rotor is allowed. The laminations have to be continuous without anything in between. The thickness of the stack plates is 0.35mm +/- 0.05mm. Only round copper wire is to be used for winding. The armature has to be permanently marked by the manufacturer, showing the number of windings and name of the manufacturer.

2.3 MODIFIED BRUSHLESS MOTORS:

- 1 Sensorless as well as sensed motors are allowed.
- 2 The motor has to be rebuildable . Ball bearings are allowed.
- 3 If the motor is sensed:  
It must use a six position JST ZH connector model number ZHR-6 or equivalent connector with 6JST part number SZH-002T- P0.5 26-28 AWG contacts or equivalent.  
Wire sequence must be as follows:  
Pin #1 - Black wire ground potential  
Pin #2- Orange wire phase C  
Pin #3- White wire phase B  
Pin #4 - Green wire Phase A  
Pin #5- Blue wire temp control, 10K thermistor referenced to ground potential  
Pin #6- Red wire +5.0 Volts DC +/-10%  
Compatible speed control must use the 6 position JST header part number X-6B-ZR-SMX-TF (Where the X denotes the stile of header), or equivalent.  
The power connector has to be clearly marked A, B, C:  
A for phase A, B for phase B and C for phase C
- 4 "05" Size specifications  
Can: Overall maximum diameter is 36,02mm measured at whatever point yields the maximum dimension, excluding solder tabs or lead wires. Overall minimum diameter is 34,0mm measured at whatever point yields the

maximum dimension, excluding solder tabs or lead wires. Maximum length is 53,0mm measured from the mounting face of the motor to the furthest most point of the end bell, not including solder tabs, lead wires or original manufacturer's logo or name. Minimum length is 50,0mm measured at whatever point yields the maximum dimension, excluding solder tabs or lead wires.

Motor mounting holes must be on 1,00 inch (25.0 - 25.4mm) centres.

Stack/Stator: The stack or backiron must be continuous. The laminations have to be one after the other without anything in between. Stack/backiron minimum length 19.3mm, maximum 21.0mm. The thickness of the stack/backiron laminations is 0.35 +/- 0.05mm. All laminations must be of the same material. Inside diameter of stack or windings equals the central space between the laminations or assembly of windings and must accept 'plug' gauges of 12.5mm minimum, 16.0mm maximum. These dimensions to be measured with the centre of the 'plug' gauge in-line with the centre of the motor can. (ie. concentric to can).

Winding: Delta and Y wounded stators are permitted. Only circular (round) pure copper is permitted. There is no turn limit.

Rotor: Output shaft diameter must be 0,125" (3.175mm). Only one piece, two poles Neodymium or Ferrite magnetic rotors are permitted.

Magnet: Minimum length 23,0mm. Maximum 27,0mm. Magnet minimum diameter 12,0mm, maximum 15,5mm.

- 5 All motors must have the original manufacturer's logo or name permanently marked by the manufacturer into the end bell or end-plate.

2.4

'SPEC' BRUSHLESS MOTORS (17.5T, 13.5T and 10.5T 'wind' limit)

The following rules have been agreed by various International organisations.

- 1 Only sensored motors are allowed in the Spec. classes.
- 2 The motor has to be rebuildable. Ball bearings are allowed. The motor must be constructed to allow easy replacement of the; rotor, bearings and front End-Bell.
- 3 Sensor connection requirements:

The motor must use a six-position JST ZH connector model number ZHR-6 or equivalent connector with 6 JST part number SZH-002T-P0.5 26-28 awg. contacts or equivalent.

Wire sequence must be as follows: -

Pin #1 - Black wire ground potential

Pin #2 - Orange wire phase C

Pin #3 - White wire phase B

Pin #4 - Green wire phase A

Pin #5 - Blue wire temp control, 10 kThermistor referenced to ground potential

Pin #6 - Red wire + 5.0 volts d.c. +/- 10%.

Compatible speed control must use the 6 position JST header part number X-6B-ZR-SMX-TF (where the X denotes the style of the header), or equivalent.

The motor power connectors have to be clearly marked A, B, C.

A for phase A. B for phase B. C for phase C

It is not mandatory that sensored Speed Controls have to be used, or that the sensor 'harness' has to be connected.

- 4 The Can. (Based on `05` size specifications).

The overall dimensions of the assembled motor do not include: - solder tabs, lead wires or the original manufacturer's logo or name.

Overall maximum diameter is 36.02mm measured at whatever point yields the maximum dimension. Overall minimum diameter is 34.0 mm measured at whatever point yields the minimum dimension. Maximum length is 53.0 mm measured from the mounting face of the motor to the furthest point of the end bell. Minimum length is 50.0 mm measured from the mounting face of the motor to the furthest point of the end bell. Motor mounting holes must be on nominal 25.0/25.4 mm centres.

- 5 The Stack/Stator: Slot-less stators are not allowed. The stator must be continuous laminations having the same overall shape, being one after the other without anything in between. The laminations must be of one homogeneous material without cut-outs, holes or hollow sections other than for the three slots of copper coil wires and the three grooves for the screws used to hold the entire assembly together. Stator minimum length 19.3 mm, maximum 21.0 mm. The thickness of the stator laminations is 0.35 +/- 0.05 mm. The Inside diameter of the stator must accept a 'plug gauge' of 14.50 mm +0/- .005 diameter, clearing the stator, plus its windings and the electrical collection ring at any end of the stator.
- 6 The Winding: Only three slot (phase) "Y" (star) wound stators are allowed. No delta wound stators allowed. Only circular (round) pure copper magnet wire permitted. The three slotted stator must be wound with: -  
 17.5T Class:- 17.5 turns of 2 x 20 awg. (or 0.813 mm) maximum wire dia.  
 13.5T Class: - 13.5 turns of 2 x 21 awg. (or 0.724 mm), & 2 x 23 awg. (or 0.574 mm) maximum wire dia.  
 10.5T Class: - 10.5 turns of 2 x 20 awg. (or 0.813 mm), & 2 x 22 awg. (or 0.643 mm) maximum wire dia.  
 Dimensions are before lacquer coating
- 7 The Rotor: Shaft diameter must be 3.175mm where the pinion gear locates. Only one piece, two pole Neodymium bonded or sintered, or Ferrite (ceramic) magnetic rotors are permitted. Magnet length will be 25.00 +/- 1.00mm, not including any non-magnetic balancing aids. Magnet outside diameter will be 12.20/12.51 mm (min./max. with no further tolerance) for the entire length of the magnet. The shaft outside diameter where the magnet is mounted will be 7.25mm +/- 0.15mm, with this diameter extending beyond the magnet to facilitate measurement.
- 8 All motors must have the original manufacturer's logo or name moulded/engraved into the end bell/plate. A unique marking or feature that is difficult to remove must be incorporated into the assembled motor to identify the motor is either a 17.5T, 13.5T or 10.5T Spec. Class motor.

### 3 BATTERIES

EFRA approved cells can be NiCd, NiMH or Lithium based (LiPo/LiFe). Each Electric Section will define which types of cell are allowed at EFRA events and the number of cells and/or nominal rated voltage.

- 3.1.1 NiCd or NiMH cells rated at 1.2 volts nominal can be approved, but must conform to the following :-  
 The size of the individual cells to be :- Diameter 23.0 mm +0/-1 mm, Overall length 43.0 mm +0/-1.5mm. Measurements include original manufacturers heat shrink. Overall length is the maximum length of the complete cell including the positive button, before attaching/soldering any link wires, connectors or battery bars. Dimensions taken at ambient temperature and at 90 degrees to the centre-line of the cell. The original manufacturers of cells are allowed a maximum of +/- 2

grms. tolerance on the nominal weight of the cell stated on the technical specification/data sheet submitted at the time of approval and is valid for virgin cells. Weights to conform to EFRA cell approval list for cells approved from Jan. 2007 onwards. Existing approvals having a weight tolerance outside +/- 2 grms. will be adjusted accordingly.

It is known that fast charging may result in cell distortion. However from 1st April 2008, cells may never exceed 43.0 mm.

3.1.2 Lithium Based (LiPo/LiFe) Batteries can be approved, but must conform to the following :-

1. Lithium Based (LiPo/LiFe) battery packs must have a hard, protective case that completely envelopes the cell(s). The case should be made from ABS or a similar material. The two halves of the case must be factory sealed in a way that any attempt to open the case will destroy the case. The only opening in the case that is allowed, is for the exit of wires.

The maximum case sizes are as follows:

2S Batteries:

Length: 139.0 mm.

Width: 47.0 mm. (The max. width includes any side exit wires).

Height: 25.10 mm. ( Chassis location features additional to this dimension are allowed)

Saddle-Pack cells are allowed, but must comply with the above dimensions. Saddle-Pack cells must have a combined dimension of 139.0mm max when placed end to end.

1S Batteries:

Length: 93.0mm.

Width: 47.0mm. (Side exit wires are allowed outside this dimension).

Height: 18.5mm. ( Chassis location features additional to this dimension are allowed)

2. Individual cells used in the construction of the battery pack shall be rated at (LiPo 3.7/LiFe 3.3) volts nominal. Individual cells may be wired in parallel. For 2S Packs, the maximum connection 'In Series' is two, to give a Final pack voltage of (LiPo 7.4v/LiFe 6.6v) nominal. For 1S Packs, cells can only be connected in parallel to give a Final pack voltage of (LiPo 3.7v/LiFe 3.3v) nominal.
3. The battery pack shall have leads extending from the case for the positive and negative electrical connections using wire of adequate size to handle discharge rates acceptable to racing applications. Alternatively, the case shall have internal connection points for these wires clearly marked positive and negative so the user can apply the lead wires. Any type of metal connections that are incorporated in the battery pack must be substantially below the major surface of the plastic casing, to prevent any 'short circuit' if placed on a conductive surface.
4. The case must have the original suppliers label intact, stating the rated voltage and the chemistry (Lipo/LiFe).. The Brand name/logo shall be easily readable.
5. All LiPo/LiFe packs must be charged with a LiPo/LiFe-capable charger using the industry standard CC/CV (Constant Current/Constant Voltage) charge profile.
6. 2S LiPo/LiFe batteries may be charged to a maximum of 8.40v (LiPo) resp. 7.40v (LiFe).



1S LiPo/LiFe batteries may be charged to a maximum of 4.20v (LiPo) resp. 3.70v (LiFe).

Overcharging is a serious safety hazard and will not be tolerated.

7. Any competitor found to be charging cells using a charger that is not specifically designed for LiPo/LiFe cells, or using a charge profile other than the industry standard CC/CV, will be penalised at the event.

Any competitor found to have charged LiPo/LiFe cells to above the values detailed in rule 3.1.2 (6) above will be penalised. The different guidelines for use and homologation of LiPo/LiFe-Batteries are published on the EFRA webpage ([www.EFRA.ws](http://www.EFRA.ws)). A copy of the guidelines for the end-user must be included in the driver's packages for EC's.

3.2. Battery Approval Processes.

3.2.1 NiCd and NiMH-cells:

Any new NiCd or NiMH must be commercially available for a reasonable time before it can be used at an EFRA event. Therefore any new cells have to be submitted to the EFRA Section Chairman for approval.

A minimum of six individual cells have to be received by 1st. December, together with a written technical specification/data sheet from the original cell manufacturer, which must include: - dimensions and weights with associated tolerances. Samples submitted are required to closely represent the weight range stated. Additional documentation is required to show that a minimum of 20,000 individual cells have been received by distributors or commercial outlets associated to the hobby industry within the EFRA countries, by 31st. Dec of the year submitted. Subject to the Chairman being satisfied that the new cell conforms with technical specifications and commercial availability, the cell will be legal for use from the following April 1st. Cells received after the above submission dates will not be included on the EFRA approved list for the following year. Any changes to the technical specifications or visual appearance of the cell/ heat shrink after the original approval will require re-approval. Any new Lithium Based (LiPo/LiFe) battery must be commercially available for a reasonable time before it can be used at an EFRA event. Therefore any new battery has to be submitted to the EFRA Section Chairman for approval.

3.2.2 Lithium based batteries:

For 2010 approval: -

2S Batteries -- A minimum of one individual battery has to be received by 31st. Dec. 2009.

1S Batteries -- A minimum of one individual battery has to be received by 31st. DEC. For subsequent years, the submission date for 2S and 1S battery samples will be 1st Dec.

Each individual battery must have safety test certification in accordance with UN Tests, detailed in Part 3, Sub-Section 38.3 of the UN Manual of Tests and Criteria.

Subject to the Chairman being satisfied that the new cell conforms with technical specifications and commercial availability, the cell will be legal for use from the following April 1st. Cells received after the above submission dates will not be included on the EFRA approved list for the following year. Any changes to the technical specifications or visual appearance of the battery or casing after the original approval will require re-approval.

- 3.3 1/12th Cars will be driven by a LiPo 1S at 3.7 Volt nominal or a maximum of four NiCd or NiMH cells at 4.8 volt nominal, Receiver batteries are allowed.

- 3.4 1/10 Touring scale cars will be driven by a maximum of five NiCd or NiMH cells, or a lithium based (LiPo/LiFe) battery. Maximum nominal voltage is 7.4 V/ 6.6 volts. Receiver batteries are not allowed.
- 3.5 1/10 Offroad scale cars will be driven by a maximum of six NiCd or NiMH cells, or a lithium based (LiPo/LiFe) battery. Maximum nominal voltage is 7.4 V/ 6.6 volts. Receiver batteries are not allowed.
- 3.6 Batteries may not be charged nor changed during a race
- 3.7 Only batteries appearing on the official EFRA website will be legal for use in EFRA sanctioned meetings.
- 3.8 All previously approved batteries may be used for their lifetime or until their specifications no longer comply with the original one that was approved. It is the driver's responsibility to prove the legality of his cells in case of doubt
- 4. ELECTRONIC DRIVING AIDS**
- 4.1 The radio control receiver in the car may operate steering and motor management. A separate battery supply for the powering of the timing equipment is allowed. Using the receiver to capture electrical signals from sensors carried in the car is prohibited, be it wireless or not.
- 4.2 Automated steering, gyroscopes to control car movement, traction control, active suspension are not allowed
- 4.3 The speed controller may have a device to limit the current/voltage passed from the batteries to the drive motor (e.g. timed delay, current limiter, keyboard programs) as well as a passive data recording device but setting or programming of these devices must only be possible whilst the car is stationary.
- 4.4 No other signals than these for the official lap counting transponder may be sent from the car.
- 4.5 Any competitor found in contravention of the spirit or fact will be disqualified from the meeting. The race organiser has the right to inspect any car, its components and transmitter at any time during the race event.
- 5. DRIVER PROCEDURE**
- 5.1 Before your heat, if needed collect the auto timing equipment from dispatch and fix it to the car.
- 5.1.1 When hand out auto-timing equipment is used, it is the driver's responsibility to fit it appropriately to the car and to remove it after timed heat if required.
- 5.2 When a personal transponder is used the driver is entirely responsible for the efficient functioning of the device.
- 5.3 As soon as race control allows, collect your transmitter, switch on and drive car to the start line.
- 5.4 When your heat has finished. Return transmitter, retrieve your car, switch off and bring it to scrutinizng with the handout auto timing equipment if required.
- 5.5 Marshal the heat following your own at the numbered position corresponding to your car number.
- 5.6 Collect your car from scrutinizng after marshalling.
- 5.7 The race director may demand the drivers to stand on the indicated positions on the rostrum.
- 5.8 The race director has absolute authority at the meeting but refer to your team manager if you encounter problems.
- 5.9 It is not allowed to enter/access the rostrum until the previous race is declared over by race control. It is not allowed to leave the rostrum before the race is declared over by race control. Penalties can be applied to competitors that do not adhere to this procedure.

## 7. EUROPEAN CHAMPIONSHIPS

- 7.1 European Championships will take place every year there is no World Championship in the concerned class held within Europe. However the general meeting can decide otherwise if deemed to be in the interest of the sport.
- 7.1.1 European Championships are held in the following classes:  
 1/10 Off-Road  
 1/12 Modified  
 1/10 Touring Cars  
 1/12 10.5T Spec. Brushless or 19T Brushed Motors  
 1/10 Touring Cars Indoors
- 7.2 ALLOCATIONS
- 7.2.1 The country allocations for the EFRA European Championships will be established by the section meeting and published in the minutes.
- 7.2.2 Allocation and re-allocations are according to the general rules.
- 7.2.3 If available all countries receive re-allocated places in order of the allocation list, unless stated otherwise in this list. Any Federation requiring to be considered for re-allocations should put their request in writing to the Section Chairman no later than 1st January.
- 7.2.4 At least 100 entrants for 1/12 and 130 for the other classes (One may consider up to 150 participants if timetable and facilities i.e. driver tables etc, permit) are to be accepted for European Championships and GP's.
- 7.2.5 For EC's any countries allotment is in no case to be higher than 33% of the total number of allocated entries ("No-Show's" and last minute cancelling drivers are not to be considered).
- 7.2.6 a) The preceding year's European Champion will automatically be allocated a place from the EFRA allocation for the World Championships.  
 b) The reigning World Champion, if European, will automatically be allocated a place in the following two European Championships.

## 8. TIME TABLES:

- 8.1 The Race Organiser should schedule all events for each day to be completed and the track closed by 18.30 hours. It is recommended to end the last day early enough to allow participants to start their return journey.
- 8.1.1 1/12th EUROPEAN CHAMPIONSHIP:  
 Friday: 1-2 Round(s) of un-timed practice (organizers discretion), 2 Rounds of timed Practice  
 Opening Ceremony (a limited heat re-seed, based on average lap times of timed practice 1 & 2, will be carried out while the opening ceremony is taking place)  
 2 Rounds of timed practice in new heat format  
 Saturday: 5 Rounds of Qualifying (In heats used for the last 2 rounds of controlled practice)  
 Sunday: 1 Round of Qualifying  
 1 Controlled practice in final groupings  
 3 rounds (legs) of finals
- 8.1.2 1/10th Touring EUROPEAN CHAMPIONSHIP:  
 THURSDAY: 09:00 Registration, Open and Timed Practice  
 FRIDAY 09:00 2 rounds of controlled Practice and 2 Qualifying Rounds  
 SATURDAY 09:00 3 Qualifying Rounds and Practice in Final Format  
 SUNDAY 09:00 second part practice in Final Format and Finals

- 8.1.3. 1/10 E off-road EUROPEAN CHAMPIONSHIP:  
MONDAY: Free practice 2WD, Registration and Technical Inspection  
TUESDAY: Controlled Practice and Qualifying Rounds 1-3  
WEDNESDAY: Schedule permitting, one hour of unofficial practice in Heat Order of Round 4  
Qualifying Rounds 4-5, Finals and Prize Ceremony  
THURSDAY: Free practice 4WD, Registration and Technical Inspection  
FRIDAY: Controlled Practice and Qualifying Rounds 1-3  
SATURDAY: Schedule permitting, one hour of unofficial practice in Heat Order of Round 4.  
Qualifying Rounds 4-5, Finals and Prize Ceremony

The Race Organiser can change the above timetable providing he does so well in advance. ALL changes to the Schedule or alterations to times of any Heats/ Finals must be clearly identified to all Team managers and Officials in written form, at least one hour before such changes take place, if any procedures are being brought forward.

## 8.2 TIMETABLE FOR GRAND PRIX MEETINGS

- 8.2.1 The timetable for Grand Prix will be left to the discretion of the Organisers taking into consideration the number of competitors in each class. Organiser can determine the Timetable for all racing

## 9. RACING FORMAT EFRA EUROPEAN CHAMPIONSHIPS AND GRAND PRIX

### 9.1 PRACTICE

- 9.1.1 Free practice for E.C. events must be allowed as stated in the concerned timetable. No practice or racing is allowed on the track for 7 days preceding this (see also General rule 8.1.).
- 9.1.2 For all EC's: 2 series of organised practice with cars grouped in heats will be held with at least one using the official time-keeping system.
- 9.1.3 During controlled practice the driver must be present and his transmitter switched on for checking radio interference.

### 9.2 START PROCEDURE

- 9.2.1 There will be a minimum of seven (7) minutes between the starts of heats, (10) ten for 1/12th.
- 9.2.2 Qualifying heats: the delayed start procedure (Staggered Start) will be used and a verbal start signal, mentioning the car number, will be given for each car. Cars must start when directed by the Start Official. Cars not starting when directed may start after the last car has crossed the lap counting loop
- 9.2.3 Finals: After the 30 seconds signal, cars not on their start grid must be placed at the rear of the grid.  
An audible signal generated by the timing equipment will be given after the "ten seconds" in a random delay of between 1 and 5 seconds.
- 9.2.4 Jump-starts (after 10-second signal) - front wheels crossing start line or their marked startbox - 10-second penalty. Front wheels crossing the line or box by one-meter: 1 lap penalty. Jumpstarts are no reason for a re-start.

### 9.3 RESTART PROCEDURE

- 9.3.1 The Race Director or the Assistant Director, in absence of the race director, may order a restart.
- 9.3.2 In the event of an aborted start procedure; race must restart at least from the "30 seconds" before the start" announcement.
- 9.3.3 If the race is stopped before the first car has completed a full lap of the track then the race will be immediately re-started after the reason for the stoppage has been

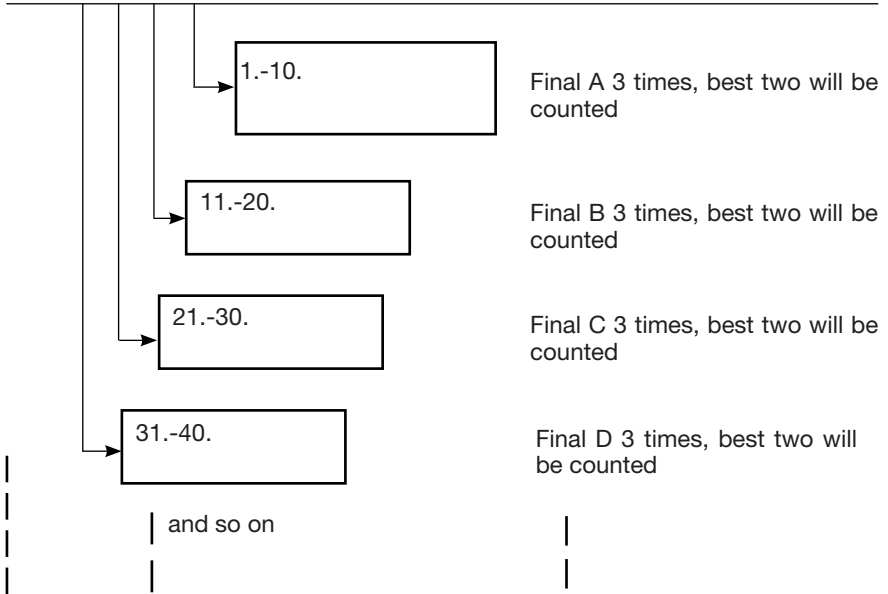

cleared. If the race is stopped after the first car has completed a full lap then the race will be re-run at a convenient time allowing for the recharging of batteries.

9.4 QUALIFYING

9.4.1 All qualifying Heats and Finals 1/10th will be 5 minutes and the last lap plus the time to complete this last lap up to a max of 40 seconds. For 1/12th the racing times will 8 minutes.

9.4.2 Qualifying will be by fastest time for 1/12th, by the 2 fastest times added together, for 1/10th Off-Road round by round system is used. For 1/10th On-road see App. 3 rule 9.4.2b.

If the 'Round by Round' qualifying method is used, the number of Rounds to count are as follows :- Six Rounds three to count, Five Rounds two to count, Four Rounds two to count, Three Rounds two to count, Two Rounds one to count. Less than two Rounds completed event null and void. All other qualifying Round scores will be discarded. Qualifying Round has to be completed for any Heats in that Round to be counted.

If the intended maximum number of Rounds cannot be completed, due to weather or unforeseen circumstances, the number of Rounds to count will follow the same format.

Fastest competitor (based on laps & time) in each Round will score zero (0) points, second place 2 points, third place 3 points, fourth place 4 points and so on. If two (or more) competitors achieve an equal time in any Round they will be awarded equal points. The next competitor not included in the tie will be awarded points corresponding to his position in the particular Round.

9.4.2a 1/10 Touring cars racing under raining conditions

If it is impossible to complete all qualifying heats under the same weather conditions, (wet, semi wet or total dry) the following rule will become effective:

Before the start of every heat the race director has to announce if it will be a dry heat or a wet heat.

The race director has also the chance of declaring that the actually started racing heat is now running under wet conditions, just as well as after the ended racing heat, if the average lap times during the heat are (or were) becoming more than 20% slower.

If every qualify round had at least one dry race cycle every round will count. If not all qualify rounds had at least one dry race cycle only the wet rounds will count

- 9.4.2b At the start of the event on Team Managers (on Friday morning) meeting they will decide if the qualifications will be declared dry or wet based on the weather.
- a. If it will be declared dry then round by round point scheme will be used where all drivers will be awarded points based on their finish against all others for each round.
  - b. If it will be declared wet then 2 fastest times will be used.
- 9.4.3 In the event of a tied position the driver with the single highest finishing position in either of the best two rounds that counted will be awarded the tie. In the event of a continuing tie then the laps and times from the best result in points will be compared. The driver with the fastest laps and time will be awarded the tie. In the case of a continuing tie, then the times from the second best scores will be compared.
- 9.4.4 When a driver incurs a penalty which results in his time and therefore points in any Round being disallowed, then all drivers below the disallowed position will move up one place. (In the event the penalized driver is a tie on obtained points the one with the best time will be lost).
- 9.4.5 The qualifying heats will be a maximum of 10 drivers and where possible equal number of drivers in each.
- 9.4.6 Cars will start in one line across the track in staggered start mode for the qualifying heats.
- 9.4.7 During the first round of qualifying, heat-starting order can be determined by lottery, or by the driver's performance in controlled practice based on his 2 best consecutive laps during the last round of controlled practice. During further rounds, heat-starting order will be by the single fastest time of drivers in their heat. This will apply whether the Fastest Time Qualifying System or Round by Round System is used.
- 9.4.8 In order to give drivers an equal chance during qualification, organiser may reseed these drivers that are obviously way above or under the average in their group into a more suitable heat whenever possible.
- 9.4.9 Off road heats will be run in the following sequence for the 5 qualifying rounds:  
Round 1: 1, 2, 3, 4, 5, 6, 7, 8, 9, 10, 11, 12, 13  
Round 2: 4, 5, 6, 7, 8, 9, 10, 11, 12, 13, 1, 2, 3  
Round 3: 7, 8, 9, 10, 11, 12, 13, 1, 2, 3, 4, 5, 6  
Round 4: 10, 11, 12, 13, 1, 2, 3, 4, 5, 6, 7, 8, 9  
Round 5: 13, 12, 11, 10, 9, 8, 7, 6, 5, 4, 3, 2, 1.  
On road heats will always be run from 1 to 15.
- 9.4.10 If the number of Heats differs from the format detailed in 9.4.9, or if the event is planned with more/less Rounds, a sequence following this general theme has to be used.
- 9.4.11 The qualifying results will determine the composition of all finals with the top 10 proceeding to the "A" final and so on down.

- 9.4.12 Off road: One round of controlled practice using the official time keeping will be organized for the A finalists. On road: A controlled practice will be applicable to all finals.
- 9.4.13 Qualifying results will be published after each round
- 10 FINALS**
- 10.1 There will be 10 drivers in all finals where possible. Finals will be organized for all competitors.
- 10.2 The winner determined from the combined A finals will be the champion. If the A finals cannot be completed, the awards will be made based on the final Qualifying positions.
- 10.3 Off Road: The "A" final will be run in three legs. All other Finals will be one leg. Each race of the main "A" final will be considered a separate race. The finals will be run from slow to fast with the 3 legs of the "A" final in between.  
On Road: All finals will be run in 3 legs from slow to fast.
- 10.4 If three leg finals are run, then the best 2 out of 3 to count.
- 10.5 The winner of a final gets 1 point; the second gets 2 points and so on up to 10 points for the 10th driver. In the event of a tie regarding time in a Final, the points will be equally awarded to each driver and the next driver not tying will be two points more.
- 10.6 In the event of a tied position the driver with the single highest finishing position in either of the best 2 finals that counted will be awarded the tie. In the event of a continuing tie then the laps and times from the highest finishing position will be compared. The driver with the fastest laps and time total will be awarded the tie. In the case of a continuing tie, then the times from the second best position will be compared.  
When some drivers of a final do not run a final, they will be awarded the remaining points in the order of their car numbers.
- 10.7 Cars, which do not pass the start/finish line after the prescribed race time, will be classified according to the number of laps recorded. The "A" finalist with the lowest number of points will be the European Champion or the winner of the grand prix.
- 10.8 All final results will be published at least 10 minutes before prize giving.
- 10.9 There will be awards at least for all "A" finalists, and the winners of any other final. If no round of Final(s) are completed the results of the event are taken on qualifying positions.
- 11. TECHNICAL INSPECTION**
- 11.1 All cars may be called for technical inspection at any time but must always be presented for scrutinizing immediately after completing their heat, qualification or final.
- 11.2 Failure to meet the technical rules will result in loss of the concerned heat result.
- 11.3 Non-compliance obviously resulting from race incidents will not be accounted for at scrutinising
- 11.4 After "A" finals the cars must be collected and impounded by organiser's staff ("park fermée").
- 11.5 The motors of the top 3 finishers may be dismantled in order to check their conformity with the rules.
- 11.6 It is allowed to change the chassis of the car, providing the replacement is of the same design, specifications and material as the original item that was registered prior to the start of racing. The new chassis has to be registered and presented to the authority.

- 11.6.1 A second chassis, prepared for wet weather racing may be submitted for technical inspection. This chassis may only be used when the race director has called either the heat or final as being a 'wet race'.
- 12. GENERAL REQUIREMENTS FOR COMPETITION CARS IN ELECTRIC CLASSES**
- 12.1 Cars must be realistic and when initially entered in the meeting have neatly finished and complete body shells.
- 12.2 Open cockpit cars must have a realistic driver figure fitted in an appropriate position at all times when racing. This consists of at least a driver's head/helmet and should be painted in a realistic appearance, colour and garb.
- 12.3 The body and chassis must be securely joined at all times when the car is on the track. Driving on the track without body is not to be allowed at any time.
- 12.4 All cars shall have identifying numbers in at least three positions, right, left and on front of the car.
- 12.5 No car shall be constructed so as to be dangerous or damage the track surface or other competitor's cars.
- 12.6 The cars must allow fitting a time keeping transponder in a suitable position with the correct orientation.
- 12.7 Any type of speed controller, not causing interference's of any kind to lapcount, computers, transmitters etc., may be used, but it must be contained within the car and not protrude through the body shell.
- 12.8 All cars must have a transparent windscreen. Open or painted windscreens are not allowed except for models of prototypes that did not have windscreens.
- 12.9 Side or rear windows must be clear. The driver may have his name on the side window in the same scale as the car.
- 12.10 Openings in the body must be appropriate to the full size prototype (Scoops, vents etc.).
- 12.11 Wheel arches must be cut out if the prototype ran that way.
- 12.12 Tyres must be black except sidewall detailing.
- 12.13 Openings for wing mount or antenna shall provide no more than 10 mm clearance.
- 12.14 Definition of a wing: A wing is an additional item attached to the car.
- 12.15 Definition of a Spoiler: A spoiler is that which is moulded in the body.
- 12.16 Spoiler and side dam dimensions include that which is moulded into the body.
- 12.17 Bumpers are not required. If fitted, bumpers must be constructed so as to minimise injury that may result from being hit by a car. The overall width may not exceed the overall width of the front of the car, including wheels.
- 12.18 Wire bumpers shall be made of wire between 2.5 mm and 4 mm in diameter. Bumpers made from sheet type material shall be between 2.5 mm and 6.5 mm thick, with all exposed edges smooth and well rounded. Closed cell foam (i.e Pu-RIM) bumpers may be 2cm thick  
Rigid blade-like bumpers made of hard, non-resilient material such as metal, brittle plastic, plywood, masonite etc., are not allowed.
- 12.19 All weight minima are applicable to cars equipped with fixed personal transponder as well as for those using (hand-out) auto-powered transponders. The later are to match the minima including transponder.(whatever the type)



## **B REQUIREMENTS FOR ELECTRIC ON ROAD CLASSES**

### **1. GENERALITIES**

1.1 On Carpet tracks a minimum ground clearance of 3mm (excluding spur gear) for 1/12 is mandatory at the start of each heat and final.

### **2. BODIES:**

2.1 Any newly homologated bodies must have the part number moulded into the front windscreen.

2.2 Body cannot be trimmed higher than lower body trim lines.

2.3 No portion of chassis, wheels and tyres, or equipment may extend beyond body except to the rear. (Exception -Formula car suspension chassis and abbreviated bodies with no engine cover).

2.4 Wheel nuts and/or axles must not protrude more than 1.5 mm beyond the wheels

2.5 No more than 1.5 mm of wheel outside diameter may be exposed on the outside of the wheel (i.e. not covered by the tyre). If wheel discs are used they should be secured by a screw or clip.

2.6 In all classes where possible, an 8th scale number must in addition be placed on the roof of the body (NASCAR style) for absolute best identification. Numbers on front windscreens must be avoided

2.7 The organizers will supply the numbers.

### **3. ROLL-OVER MASTS:**

3.1 A rollover mast may be fitted. If so, it must have a blunt end for safety reasons, terminate in a closed loop at least 4.75 mm O.D. or a ball or button not less than 8 mm in diameter.

3.2 If a rollover mast and radio antenna is fitted, the antenna must be part of the mast along its length. Max. Height from ground 35 cm.

### **4. BUMPERS**

4.1 All cars may run a rear bumper, which must be behind rear tyres.

4.2 If used, front bumpers must be flat; parallel to the ground in all directions.

### **5. TYRE ADDITIVES / TRACTION IMPROVING TREATMENTS:**

5.1 All Tyre treatments, governed by health, nuisance and track damage considerations will be at the discretion of the organisers and EFRA. I.e. Normally only odourless tyre cleaners or traction additives will be allowed.

5.2 Allowable products for carpets are: Corally TC2 (Jack the gripper), LRP Top grip carpet, Orion Foam TQ. and CS Grip tyre conditioner.

Allowable products for Tarmac use: Orion street juice, Jack the Gripper, Trinity Tyre Tweak, GM X grip 3, LRP top grip Asphalt.

5.3 Any other product can be added to the list by request and once checked by section chairman and organiser as being ok.

5.4 European Championships: A list of allowed substances or products will be published with the entry form.

5.5 It is recommended that the chemical components of these products must be harmless for people and environment.

Liability at the use of tyre additives lies at the user and manufacturer.

### **6. PARTICULAR TO 1/12th SPORTS CARS**

#### **6.1 BODIES:**

6.1.1 Body shells must be submitted to the EFRA Body shell Homologation Officer for approval. A list of homologated bodies must be sent with the drivers package and to the organisers and be available on the EFRA website.

The following is the specification for approval of 1/12 Prototype Sports car body shells. They should be used by the Homologation officer to enable clear and

consistent application of standards for future approvals,  
Lower body cut line is to be used as the reference plane for all height dimensions.  
Minimum cockpit height – Closed cockpit – 55mm (Excluding any air scoops / air boxes)  
Minimum cockpit width – Closed cockpit – 70mm (Measured at the point it intersects with the side pod)  
Minimum cockpit width – 55mm (measured at the lower window line)  
Minimum Roll bar height – Open cockpit – 55mm  
Maximum distance from Drivers helmet to top of roll bar – Open cockpit – 11mm  
Minimum cockpit width – Open cockpit – 65mm (Measured at the point it intersects with the side pod)  
Minimum front wheel arch height – 46mm (Including vents) (measured at a point 15mm from edge of body)  
Minimum rear wheel arch height – 50mm (measured at a point 10mm from edge of body)  
Maximum overall width – 174mm  
Minimum overall width – 168mm  
Max. wing / spoiler height – 65mm  
Max. front overhang (From centre of front wheel) – 70mm  
Max. rear overhang (from centre of rear wheel) – 70mm  
Max. length overall – 340mm  
Minimum side pod height – 30mm  
The side dam must blend fully (disappear) into the main body shape within 110mm of the rear edge of the body/side dam.  
Max side dam height – 72mm  
The body side forward of the side dam must have a radiused edge, no lips or upward extensions are acceptable  
Bodies must be a reasonable representation of a full size LMES / ALMS / LMP / WSC prototype.  
Open cockpit cars to have twin roll bars as current LMES / ALMS  
Open cockpit cars must have a representative drivers helmet and cockpit opening  
The name of the prototype must be used for the homologation process.  
The name of the prototype does not have to be used for general sales and marketing.  
Only fins or strakes that are present on the full size prototype will be allowed.  
The body must not be cut above the lower cut line  
Cut-outs in the shell will be allowed only if clearly defined on the full size prototype  
Once Homologated there must be no changes to the design, trim lines, detail lines or any feature of the body. All changes will require resubmission for approval and an additional revision letter added to the part number- Example 15001A - Original - 15001B for a 2ndRev. Etc  
The manufacturer's par number must be clearly marked on the shell alongside the windscreen area  
Bodies complying to the existing homologation will be allowed until Oct 1st 2010. All new homologation must meet the above criteria.

- 6.1.2 Wheel cut-outs may not be more than 15 mm larger than tyre radius (Exception - scale size and/or shape wheel cut-outs). Wheel wells must be cut out if those on the original car were cut out.
- 6.1.3 Only one wing is allowed on the car unless the actual car had a second wing. The second wing must be scale within 10% in size and location. The wing may be not closer than 6.5 mm to any part of the body other than the tail fins or side dams.

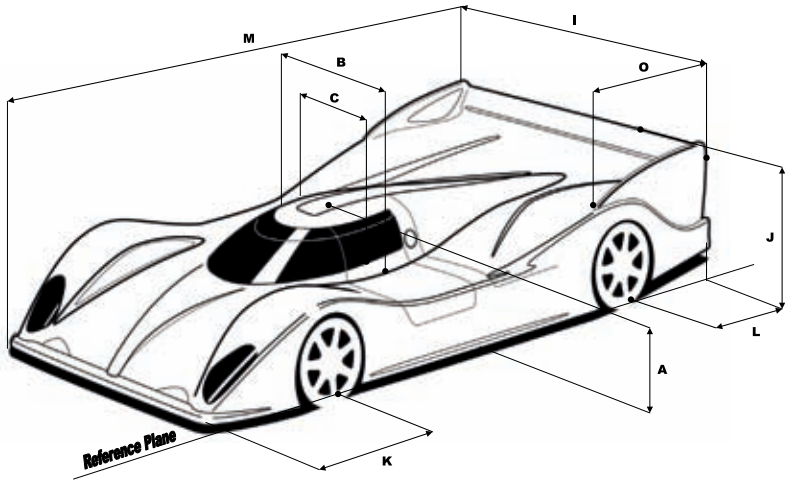

A. Min 50mm	J. 100 to 170mm
B. Min 50mm	K. Max 40mm
C. Min 50mm	L. Max 70mm
D. Min 50mm	M. Max 240mm
E. Min 50mm	N. Min 30mm
F. Min 40mm	O. Max 110mm
G. Min 50mm	P. Max 70mm

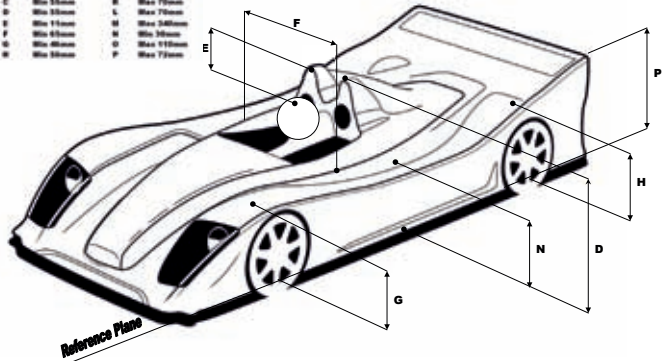

## 6.2 MEASUREMENTS AND WEIGHTS

Maximum overall width of the car: 172 mm (Excluding shell)

Minimum weight: 730 grams.

Wing: Maximum width: 172 mm, the wing profile has to fit in a rectangle of 52mm (height) x 26mm

Spoilers: Max. Spoiler height: 25 mm, max length 35 mm. These dimensions include the moulded in portions of the body, the use of a gurney flap to extend the wing length is acceptable.

Bumper: May extend 6.5 mm beyond side of body or to 172 mm whichever is less. May extend 13 mm forward of body, but in same shape as body.

Wheel rim diameter: Minimum 29 mm and Maximum 38 mm. (Including all non-rubber parts of the wheel and tyre).

Rectangle max 52 x 26 mm

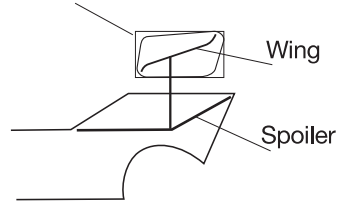

6.3 TYRES

6.3.1 All tyre sizes apply at the start of the race.

6.3.2 Tyres Minimum width 13 mm. Maximum width 40 mm. The tyre width is measured at the widest part of the tread or sidewall.

6.3.3 Any tyre diameters will be allowed. The diameter must be maintained over at least the minimum width of the tyre.

6.3.4 Each tyre on the car must only be constructed from 1 compound (shore rating/density) of foam rubber.

6.3.5 Tyres must not be wet or greasy from additive at the start of a heat or final.

6.3.6 Technical Inspection can demand to check the tyres prior to each start

**7. PARTICULAR TO 1:10 ELECTRIC SALOON CARS**

7.1 BODIES:

7.1.1 Only bodies that comply to the body guideline for 1:10 electric touring car bodies as per drawings in this handbook of real touring cars that have a minimum length of 4200mm in the original car are allowed. No GT or Sports car bodies allowed. All Touring car bodyshells to be submitted to the EFRA Bodyshell Homologation officer for approval.

7.1.2 Bodies are not to be cut above the bottom line of the rear bumper.

7.1.3 A wing may be fitted to the rear of the body but not on the roof or above the roofline.

7.1.4 The wing may overhang the rear of the body of the car by 10 mm.

7.2 MEASUREMENTS AND WEIGHTS

Maximum overall width (with body) 200 mm

Maximum overall width (without body) 190 mm

Minimum height (to top of the roof) 115 mm (ready to run)

Maximum wheelbase 270 mm

Minimum weight 1350 gram

Wing: maximum width 190 mm. The wing profile has to fit in a rectangle of 25mm (height) x 40

Maximum wheel rim diameter (excl. ribs) 50 mm

The use of multiple-speed transmissions (gearboxes) and slipper clutches is not allowed.

All cars must have independent suspension operating on all four wheels (no PRO 10 cars allowed).

Only a fixed single ratio transmission is allowed and it may not include a mechanical device/s between the drive motor output and the gearbox input for the purposes of controlling torque (e.g. slipper clutches).

7.3 TYRES

7.3.1. Only moulded tyres are allowed (no sponge tyres).

Maximum tyre width 26 mm

Minimum tyre width 18 mm

7.3.2. At EC's it is only allowed to use the tyres that were agreed by the section meeting at the EFRA AGM together with the race organiser (race organiser will make their recommendation). For dry weather racing there will be a single control slick tyre with insert and will come pre-glued to the wheel (insert, tyre and wheel to be same for all drivers) and commercially available via model/hobby shops. For wet/damp conditions there will also be a pre-glued control set of tyres. For use at the EC, the tyres must be bought from the organiser. For each competitor there must be at least 1 set of dry and wet weather tyres available to be bought for practice at the EC.

Price fixed for each EC event at 100E for 5 dry weather sets, this price only for tires used at event.

- 7.3.3. 5 sets of 4 dry weather tyres are allowed for qualifying, and an additional 3 sets of 4 dry weather tyres are allowed for A finals. All lower finals only one additional set of dry weather tyres. 1 set of 4 wet weather tyres are allowed to be used for both qualifying and finals.
- 7.3.4. Tyres from qualifying may be used in the finals
- 7.3.5. For wet/damp conditions a treaded tyre may be used but only when the Race Director gives his permission. This treaded wet tyre does not form part of the limited number of sets.
- 7.3.6. Tyres/wheels may not be modified. Changing of tires between drivers is not allowed. Drivers must have their wheels and tyres marked by Technical Inspection and this marking can be done at any time.
- 7.3.7. The Technical Inspector must mark wheels/tyres before being presented to Technical Inspection for qualifying heats and finals.
- 7.3.8. Unmarked wheels/tyres may not be used on the car during qualifying heats and finals but are allowed for practice.
- 7.3.9. Technical Inspection shall be responsible for recording the number of tyres used by each driver.
- 7.3.10. No extra sets are allowed for a re-run of a heat.
- 7.3.11. All set of tyres for qualification have to be returned by the driver by the end of each qualification day to the organizer (tyre impound). Not returning the tyres in the announced time by the organizer will be punished with the lost of the best heat. The not returned set of tyres have to be checked and released for further use by the technical inspection.

### GLOBAL BODY SPEC ( GBS for Electric Sedans )

- |                  |                               |
|------------------|-------------------------------|
| (A) = Max 10 mm  | (F) = Max 65 mm               |
| (B) = Min 105 mm | (G) = Max 25 mm (Max 3 posts) |
| (C) = Max 85 mm  | (H) = Min 410 mm              |
| (D) = Min 90 mm  | (I) = Min 170 mm              |
| (E) = Min 65 mm  | (J) = Min 35 mm               |

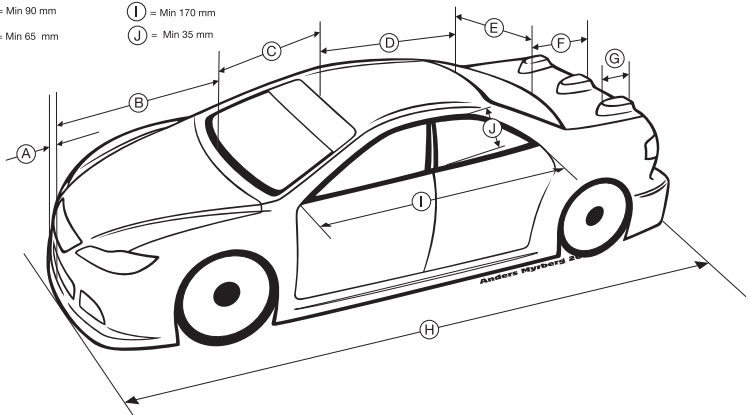

- (K) = Min 140 mm Max 155 mm
- (L) = Min 110 mm Max 125 mm
- (M) = Min 115 mm
- (N) = Max 195 mm

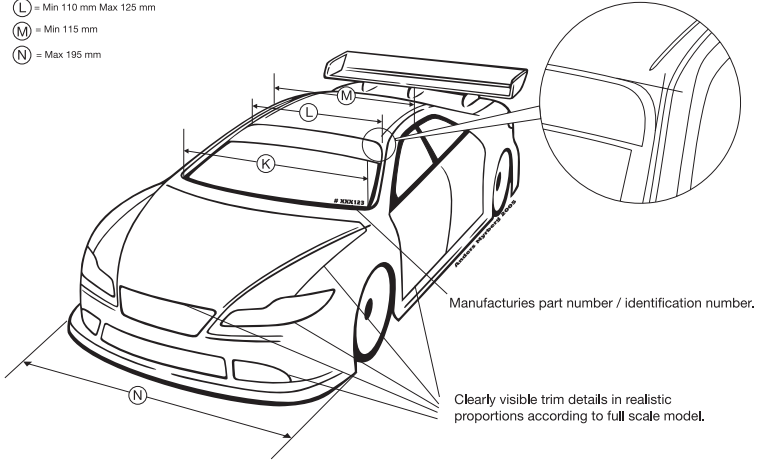

- (O) = Min 150 mm
- (P) = Min 95 mm
- (Q) = Max 10 mm
- (R) = Min 115 mm
- (S) = Max 35 mm

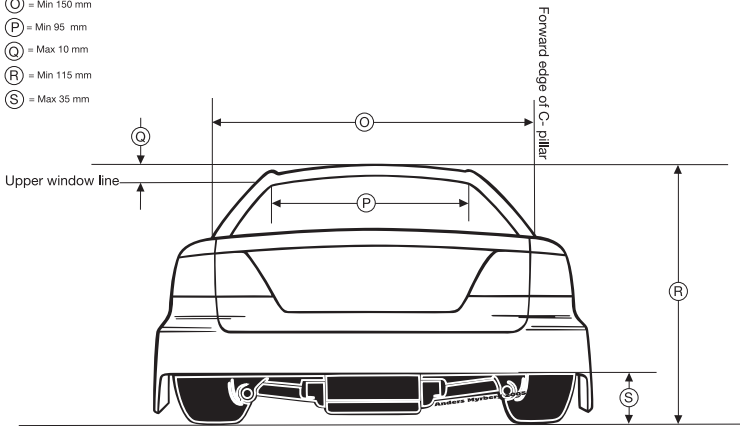

**C PARTICULARS for 1/10 OFF ROAD****1. GENERALITIES:**

- 1.1 Cars entered for off-road competitions should be reasonable representations of the style of full size cars generally accepted as being suitable for rally-cross, rallying or desert racing.
- 1.2 There are two classes of cars: 2WD and 4WD. Both must be run and drivers are allowed to enter both classes.
- 1.3 All open gears must be enclosed or protected so as to prevent injuries.
- 1.4 Any modification to the car is allowed.
- 1.5 A differential may include a mechanism for apportioning torque over the axle/s (e.g. limited slip differential). This mechanism must only be capable of adjustment manually whilst the car is stationary

**2 MEASUREMENTS AND WEIGHTS:**

- |   |  |
|---|--|
| Maximum overall length:                   | 460 mm   |
| Maximum overall width:                    | 250 mm (At any point of suspension travel)                         |
| Maximum overall height:                   | 200 mm (to be measured with the suspension fully compressed)       |
| Minimum weight 2WD cars:                  | 1.474 gram   |
| Minimum weight 4WD cars:                  | 1.588 gram   |
| Maximum size of rear wing:                | 220mm wide, the wing profile has to fit in a 80mm x 80mm rectangle |
| Maximum size of wing side-dam:            | Any side-dam has to fit an 80mm x 80mm rectangle                   |
| Maximum overall diameter of wheel & tyre: | 90mm   |
- Measuring equipment for width, length and height should be constructed preferably from metal or alternatively high quality board. The materials will be of suitable thickness to eliminate any distortion.
- Design of the equipment to allow all points of the car to be measured.

**3 TYRES**

- 3.1 Grand Prix: Any combination of commercially available 1/10th scale wheels and tyres may be used.
- 3.2 European Championships: The organizer will propose 1 type of tyre for each of the driven axles for 2WD and 4WD (2WD and 4WD do not have to be the same type of tyre). The manufacturer and full description of the tyres chosen must be given, but there remains free choice of compound. The proposed tyre choice will be ratified at the EFRA section AGM prior to the EC and provided always that the chosen tyres are commercially available throughout the EFRA Nations. The manufacturer(s) of the chosen tyres will be notified which specific tyre has been chosen as soon as the decision is finalised.
- 3.3 No metal or hard plastic may be used for spikes
- 3.4 Modifications to tyre construction and tread patterns are allowed. 'Cut and Shut' is permitted at Grand Prix only and even so if the parts of one or more different tyres are glued together, provided always that the constituent parts are all recognisable as coming from commercially available 1/10th scale tyres.
- 3.5 No sponge or foam tyres are allowed except for foam inserts completely enclosed within the sidewalls.
- 3.6 No tyre additives other than water are allowed, inside or outside of any tyre.

**4 RAIN PROCEDURE for QUALIFYING**

- 4.1 The Race Director and the Referees are jointly responsible for the decision to stop racing in the event of adverse weather conditions.
- 4.2 When Racing is suspended as per the rule above, then racing will recommence, when weather permits, with the heat that was next to be run prior to the interruption.
- 4.3 Every effort should be made by the Race Directors to make necessary repairs to the racing surface prior to recommencement of racing.
- 5 Body shell holes/vents: The front and rear ends of the shell must retain some of the original profile of the two ends of the shell. Front and rear facing areas within the body shell surface which are 'marked' with the intention of removal to form "air scoops/vents" are allowed to be removed. If no "marked" air scoops/vents are designed in the original mould to assist airflow to the motor or ESC, then material may be removed to a maximum of 10 mm. in any direction within a maximum square area of developed size 30 mm x 30 mm, in two places only. Windows are not allowed to be removed or include holes, other than for the purpose of the antenna.

