



EFRA ANNUAL GENERAL MEETING

HOTEL Sofitel, Brussels.

Belgium

3rd to 4th of November 2007

Minutes 1:10 IC Track

SATURDAY 3rd OF NOVEMBER 2007.

The meeting start at 14h00in the afternoon

1. CHAIRMAN'S WELCOME

Mr Franky Noens

Looking back at the past racing season, I have to say it was a good and fun year. First of all, I want to thank everyone involved in the organisation of a GP or EC. Without those people who are prepared to give up their holidays, mostly without compensation, it would be impossible to organise this kind of high level races.

2. APOLOGIES FOR ABSENCE

Apologies have been received from: Russia

Member Countries presents, section subscription, allocations etc:

COUNTRY	PRESENT	SECTION SUBSCR	ECB	ECB Re	ECA	ECA Re	World	World Re
AUSTRIA	Thomas Sutrich		2				5	1
BELGIUM	Willy Wuyts		9				5	
CROATIA								
CYPRUS	Costas Michaeldes						1	
CZECH REP.								
DENMARK							2	
ESTONIA								
FINLAND	Tony Raikas						4	
FRANCE	Philippe Bertrand		20				5	2
GEORGIA								
GERMANY	Weck Dieter		15				5	4
GREAT BRITAIN	Scott Nettleton		10				5	2
GREECE							3	
HOLLAND	Dave de Ruiter		6				5	2
HUNGARY			1				2	
IRELAND			5				2	
ITALY	Stanzani Guerrino		12				5	4
LUXEMBOURG							2	
NORWAY	Vivian Keller						4	
POLAND	Trella Andrzej		3					
PORTUGAL	Cesor Coelho						5	4
ROMANIA								
RUSSIA			2					
SLOVAK REP.							2	
SLOVENIA	Zarko Vuga		1					
SPAIN	Garga Javier		2				5	4
SWEDEN	Bent Andersson		5				5	4

SWITZERLAND	Camponovo Ernesto		9				3	3
TURKEY								
TOTAL			102				75	27

Other persons present:

3. MINUTES OF 2006 SECTION MEETING

4th -5th of November 2006— Brussels, Belgium

Matters arising from the minutes: Non

4. CORRESPONDENCE RECEIVED

Correspondences from the 2007 season.....Questions about mufflers,engines

5. CHAIRMAN'S REPORT

Looking back at the past racing season, I have to say it was a good and fun year.

First of all, I want to thank everyone involved in the organisation of a GP or EC.

Without those people who are prepared to give up their holidays, mostly without compensation, it would be impossible to organise this kind of high level races.

Also thanks to all manufacturers who made their contribution by means of sponsoring these events.

Both organised EC's were high level races, with sufficient people, and everything was in apple-pie order to make it a good event.

We can state we had more drivers at the EC and GP than the years before.

As this table below proves:

2006					
Slovenia	Swiss	Netherlands warm up EC A	Netherlands EC A		Total
18	8	63	142		231
2007					
Spain warm up EC	Portugal	France warm up EC B 2008	Spain EC A	Belgium EC B	
80	27	41	146	121	415

On behalf of EFRA I made many proposals to equalize technical regulations,worldwide.

Not only useful for those who attend the Worlds, but also for manufacturers.

Apparently the present 1/10th rules are quite good, seeing that we received very few proposals for change. Everyone must confess, each year cars are running faster and faster,unfortunately it is attended with more noise.

Therefore I would like to suggest to race with three chamber exhaust pipes and an INS box, starting from 2009.

It is of vital importance that we keep the noise under control, to guarantee the continuing of our class.

Unfortunately every year we see tracks which have to close because of noise problems.

Also the EC 235mm were a success, unfortunately I could not be there this year, but we can see a small increase in this class. Everyone driving with

the Porsche GT3 body, seems to call it a success. Let us carry on with this class, in a few years time we might have 100 people again on their EC. Preceding years you received dozens of pages with results below, this is in fact a heap paper which can be used better.

If you need a result, just mail me, or you can find them on the Internet.

Talking about the internet, I would like to thank all amateur and professional reporters for all their work.

Targets for next year: a perfectly organised EC B, and show the world that EFRA members organises the best world championships. To end with this: sometimes I've had rather hard disputes with organizers.

This was never meant personally, but only to reach our common target.

GP, EC and world championships simply must be the best races on earth, our participants deserve this. Thanks for everything, my friends, and I hope to see you again next year, and of course new people.

6. PRESENTATIONS FOR APPLICATIONS EC 2008 AND GP'S 2008

The section has received the following applications to host coming EFRA events. These proposals have reached us in time, not other proposal will be accepted after distribution of the agenda.

Year/Date	Alt. Date	Status	Country	Venue
August 2008		EC 1/10 th 235 mm	Holland	Heemstede
6-7 September 2008		GP-1:10 IC track 200mm	Holland	Heemstede
7-8 June 2008		GP-1:10 IC track 200mm	Italy	Gubbio

Final Race calendar 2008

Year/Date	Alt. Date	Status	Country	Venue
March		Ifmar warm-up	Portugal	Lisbon
May		EC 1/10 th 200mm	France	Ampuis
7-8 June 2008		GP-1:10 IC track 200mm	Italy	Gubbio
5-6 jul 2008		EC 1/10 th 235 mm	Holland	Heemstede
7 – 17 August		WC 1/10 th 200mm	Portugal	Lisboa
6-7 Sept 2008		GP-1:10 IC track 200mm	Holland	Heemstede
4-5 oct 2008		GP-1:10 IC track 200mm	Austria	Aigen

Future Race calendar Championships

Year/Date	Alt. Date	Status	Country	Venue
2009		EC 1/10 th 235 mm	Spain	Alcobendas (MADRID)
May 2009		EC B-1:10 IC track 200mm	Austria	Aigen-Schläg
August 2009		EC A-1:10 IC track 200mm	Italy	Gubbio

7. ALLOCATIONS

Allocations were made to each country as printed in the table form under item 2 on the agenda

8. RULE PROPOSALS

EFRA AGM 2007 - RULE PROPOSALS 1/10th IC 235mm

SECTION: Appendix 6 1/10th IC 235mm

RULE No: 5.10

The proposed rule... ...is New

...should be: deleted amended

THE RULE SHOULD BE AMENDED TO READ

EFRA approved Porsche GT3 bodies only.....

Remark:

Proposed by: EFRA Section Chairman

Seconded by: Austria

The proposal: Passed Unanimously

SECTION: Appendix 6 1/10th IC 235mm

RULE No: 5.10

The proposed rule... ...is New

...should be: deleted amended

THE RULE SHOULD BE AMENDED TO READ

Wing width **233mm** maximum
Remark:

Proposed by: EFRA Section Chairman

Seconded by: Belgium

The proposal: Passed Unanimously

SECTION: Appendix 6 1/10th IC 235mm

RULE No: 5.8

The proposed rule... ...is New

...should be: deleted amended

THE RULE SHOULD BE AMENDED TO READ

Tyre with front **31.00** max
Tyre with rear **52.00** max

Remark:

Proposed by: EFRA Section Chairman

Seconded by: Slovenia

The proposal: Passed Unanimously

SECTION: Appendix 6 1/10th IC 235mm

RULE No: 5.6

The proposed rule... ...is New

...should be: deleted amended

THE RULE SHOULD BE AMENDED TO READ

The weight limit will be checked with the cars ready to race, but with empty fuel tanks and including a transponder
minimum weight **1950,00** grams

Remark:

Proposed by: EFRA Section Chairman

Seconded by: Austria Not Seconded

The proposal: Passed Unanimously

EFRA AGM 2007 - RULE PROPOSALS 1/10th IC 200mm

SECTION: Appendix 7 1/10th IC 200mm

RULE No: 5.1

The proposed rule... ...is New

...should be: deleted amended

THE RULE SHOULD BE AMENDED TO READ

The engine may have a total capacity of not more than 2.11 cc.
They shall be air-cooled, with front rotary valve, two-stroke induction.

They engines may have a maximum of four (4) ports in the liner, including the exhaust port, seen with the piston at lowest position.

No form of forced induction is allowed. No form of variable port timing.

Only glow plug ignition is allowed. One additional gap in the bottom (skirt) of the piston is allowed. **No additional holes in the piston are allowed**

Additional slits or holes in the liner for cooling purposes are allowed as long as they do not reach the top of the piston at lowest position.

Standard and conical glow plugs allowed.

Where ever we say hole in this rule we mean a hole that is surrounded completely by material

Proposed by: EFRA Section Chairman

Seconded by: Slovenia

The proposal: **Passed Unanimously**

SECTION:

RULE No:

The proposed rule.... *...is New*

...should be: *deleted* *amended*

THE RULE SHOULD BE AMENDED TO READ

Overall dimensions:

	MINIMUM (mm)	MAXIMUM (mm)
Wheelbase	230.00	270.00
Width without body	170.00	200.00
Width with body	175.00	205.00
Length inc Body & wing	360.00	460.00
Height to the top of the roof <i>(measured with a 10mm spacer under the chassis plate on level)</i>	120.00	175.00
Wing width inclusive Side Dams	125.00	200.00
Wing		55.00
Side Dams		35.00 x 50.00
Wing overhang (at rear)		10.00
Wheel dia. (excluding tyre bead)	46.00	50.00
Wheel width (including tyre bead) and Tyre width max (across side walls):		
Front:		31.00
Rear:		31.00

Proposed by: EFRA Section Chairman

Seconded by: Germany

The proposal: **Passed Unanimously**

SECTION:

RULE No:

The proposed rule.... *...is New*

...should be: *deleted* *amended*

THE RULE SHOULD BE AMENDED TO READ

Fuel may only contain methanol (methyl alcohol) lubricating oil, a **small content of anti corrosion chemicals** and a maximum of 16% nitro methane in volume. The specific gravity of the mixture may not be heavier than 0.87. An EFRA approved fuel tester, e.g. Nitromax 16 will be available to verify fuel's conformity to the rules at technical inspection.

Any violation with fuel which means any proof of the use of other additives as mentioned will mean 5 years of disqualification from any EFRA and IFMAR event.

Proposed by: EFRA Section Chairman

Seconded by: Sweden Not Seconded

The proposal: Passed with15. for, against and ...1... abstentions.

SECTION:

RULE No:

The proposed rule... ...is New

...should be: deleted amended

THE RULE SHOULD BE AMENDED TO READ

Details of all front and rear lights, grills, air intakes, and windows must be clearly contrasted from the surrounding paintwork.

No parts of the car except the muffler outlet may protrude outside of the body shell, when viewed from above.

No parts of the car except the antenna, body posts, transponder may protrude outside of the body shell, when viewed from the side wall

No additions or reshaping to the original molded bodyshell (No Body stiffeners allowed)

Remark:

Proposed by: EFRA Section Chairman

Seconded by: Austria

The proposal: Passed Unanimously

SECTION:

RULE No:

The proposed rule... ...is New

...should be: deleted amended

THE RULE SHOULD BE AMENDED TO READ

BODIES

Bodies must be a 1:10 scale **touring car** in character reproduction of vehicles that exist or have existed. **And must be comply to the GLOBAL BODY SPEC 1/10th IC Track**

Bodies will be checked ~~send to~~ the Bodyshell ~~by the Homologation Officer~~ **for approval**.

~~The scrutiny should be done after the following procedure:~~

~~The manufacturer of a body has to send the body to the Homologation Officer within the period from December until the end of February.~~

Payment procedure for EFRA Homologation remains the unchanged.

After being checked the body will get an EFRA Number.

This EFRA Number in combination with the logo of the manufacturer has to be embossed in the body at the right upper edge of the windscreen.

At the end of March a list of all homologated bodies will be made available.

Only these bodies can be used at EFRA sanctioned events throughout the year.

A body which is sent to the Homologation Officer after the end of February can only be used in the following year.

Proposed by: EFRA Section Chairman

Seconded by: Italy

The proposal: Passed Unanimously

SECTION:

RULE No:

The proposed rule... ...is New

...should be: deleted amended

THE RULE SHOULD BE

For IC: Fix 2 types of rain tire (one slick rubber type, and one full wet tire, but both types need to be rtr). An off set which works for all cars needs to be chosen.

Proposed by: Orion

Not Seconded

SECTION:

RULE No:

The proposed rule... ...is New

...should be: deleted amended

THE RULE SHOULD BE

Proposal

Each motor must be equipped with an exhaust system and an inlet silencer (no INS for Off-Road), to reduce the amount of noise generated by the car.

The muffler must be of a 3-chamber type. No holes are allowed in the first chamber. All gasses must pass all 3 chambers. See enclosed design in appendix 8

The shape of the exhaust pipe has to be of a straight revolved (rotated) type. Any other shape like oval, or bend, or in any other form that is not reproducible by a lathe, is not allowed (this is to avoid manifolds welded to the muffler). The design of the separator between the 2nd and 3rd chamber is a simple disc with only one flat part. The gap of this flat part is for 1/8th mufflers max. 5mm, and should be positioned opposite the tailpipe. (Other dimensions see drawing)

No conical manifolds are allowed, inlet and outlet of the manifold max 13mm, measured on the inside (12mm for 1/10th). The maximum noise level for a muffler with INS box is 83 dB's, measured at ten (10) metres distance and one (1) metre high for a single car.

EFRA's definition of a noise level is always final.

Only EFRA homologated 3-chamber mufflers are allowed on EFRA sanctioned events. The EFRA homologation number must be engraved on the sidewall of the muffler. This proposal, if accepted at the EFRA AGM will be effective for 1:8 IC track as from April 1st 2008, 1:8 Off-Road as from April 1st 2008 and for 1:10th IC track as from December 31st 2008.

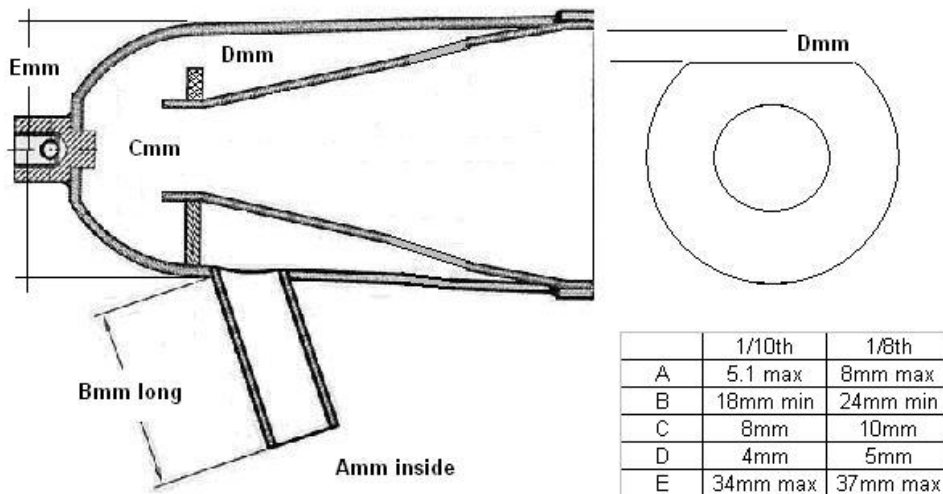

No holes permitted in the first cone. All gasses must pass the 3 chambers.

Proposed by: [EFRA Section Chairman](#)

Seconded by: Belgium

The proposal:

Passed Unanimously

Rejected with for, against and abstentions. Amended

9. ELECTION OF SECTION CHAIRMAN.

Mr Franky Noens continue for a new period

10. ANY OTHER BUSINESS,

Allocations were made to each country as printed in the table form under item 2 on the agenda. Also this year we have seen to many "No Showes". Somehow this number "No Showes" will be taken into account for the next EC's and WC's. The Section Chairman will work out a proposal for next year.

11. ITEMS FOR GENERAL DISCUSSION.

Noise problems .