



## MINUTES LARGE SCALE

**SATURDAY 5th OF NOVEMBER 2005.**

*The meeting opened at: 14:10*

1. **CHAIRMAN'S WELCOME** Mr . Wolfgang Stumpf
  
2. **APOLOGIES FOR ABSENCE: Greece, Ireland, Portugal**

COUNTRY	PRESENT	SECTION SUBSCR	EC	EC Re- allocations	Open EC F1
AUSTRIA	E.Prohaska		3		
BELGIUM	J. Poelmans		-		
CROATIA	Z. Matosic		5		
CZECH REP.					
DENMARK	B. Helmer		1		
ESTONIA					
FINLAND					
FRANCE	J.L. Molat		8		
GEORGIA					
GERMANY	T. Eisenreich		-		
GREAT BRITAIN	I. Oddie		5		
GREECE			10		
HOLLAND	C. Roskam		10		
HUNGARY					
IRELAND			4		
ITALY			8		
LUXEMBOURG	J. Mersch		1		
NORWAY	G. Lilletvendt		1		
POLAND					
PORTUGAL			3		
ROMANIA					
RUSSIA					
SLOVAK REP.					
SLOVENIA					
SPAIN	A. Pineda		5		
SWEDEN	F. Scholander		3		
SWITZERLAND	M. Strasser		10		
<b>TOTAL</b>			<b>70</b>		

Other present: L. Idengren, St. Grosch, Dallas Mathiesen

Election of two delegates to audit the minutes for that meeting:

Th. Eisenreich, Z. Matosic

### 3 MINUTES OF 2004 SECTION MEETING

6<sup>th</sup>-7th of November 2004— Rome, Italy

a) Matters arising:

**Proposed by: Great Britain**

**Seconded by: Holland**

### 4 CORRESPONDENCE RECEIVED

Complains about the ECU from Ian Oddie.

### 5 CHAIRMAN'S REPORT

This season I was present at the EFRA GP of Italy in San Lazzaro, than in Austria at the track of Kirchberg, in Croatia at the track of Zagreb and in Czech Republic, in Slavkov as the EFRA main referee. In Slavkov a small problem occurred as in the final the majority of drivers don't want to start because there was a rain shower. At least there are at first 2 starters at the line, than 4 drivers started and a 5 one decided to come later, but the final was finished in bright sunshine Than in France at the EFRA GP of Grenoble I was present as visitor. The rule clarification about the engines was done in Bologna by a request of the Italian Federation.

The EC in Sweden had hot and sunny weather, the Formula winner was Markus Feldmann from Germany, the Saloon won Cedric Prevot from France. The participation was not such high, some drivers are nominated, but don't show up, but the following Worlds in Lostallo are fully booked. The winner there was Ian Oddie from Great Britain. At the worlds the weather was not so nice, there was rain on both weekends. Before this event, there come up a discussion about the ECU of Ian Oddie. As I understand the existing rules this part is legal, so it was allowed at the EC, but banned from IFMAR for the WC. After some small changes the item was allowed.

I also was as Referee at the EFRA GP of Germany in Mühlau, rainy weather and last not least I was invited to the Off Road event in Salou / Spain, the new place of the Rallye Catalunya and there is this important Off Road show race in the drivers area of this real motorsport event. And this race was the highlight of the year in my opinion.

### 6 PRESENTATIONS FOR APPLICATIONS EC 2006 AND GP'S 2006

Date	Alt. Date	Status	Country	Venue
		EC	Greece	Fanatix/Athens
19. -20.8		GP	Great Britain	Brooklands
April		GP	Italy	San Lazzaro di Savena (BO) not in time
7. -8. 10		GP	Spain	Alcobendas (Madrid)
28,29, 30th April		International	Croatia	Zagreb
9. – 11. 06.	23. – 25.06	GP	Czech Republic	Slavkov
3. – 9. 07.	17. – 23.07	Open EC F1	Czech Republic	Slavkov
July		Open EC F1	Austria	Stöhr Ring
21. 23.07		Open EC F1	Germany	Mühlau
27.-28.05.		GP	Switzerland	MRTM Lostallo
2. - 3. 09	Sep 2006	GP	Germany	Munster
13.-14. 05	June	GP	Austria	Kirchberg Stöhr Ring
		GP	Sweden	Gothenburg / not in time
25. - 26. 03.		International	Spain	Salou / LS off road

## 2007 – EC's

Date	Alt. Date	Status	Country	Venue
July		EC TC	Austria	Stöhr Ring
July		EC TC	Germany	Leipzig
July		EC TC	Italy	Bologna // not in time

These proposals have reached us in time, not other proposal will be accepted after distribution of the agenda.

## RACE CALENDAR

### 2006

Month	Date	Status	Country	Venue	Add info
April	28.-30.	International	Croatia	Zagreb	
May	13. -14.	GP	Austria	Kirchberg Stöhr Ring	
May	27.-28.	GP	Switzerland	MRTM Lostallo	
June.	9. - 11.	GP	Czech Republic	Slavkov	
July	3.-9.	EC	Greece	Fanatix/Athens	
July	21. 23.	Open EC F1	Germany	Mühlau	
July	29.-30.	24 Hours	Switzerland	Switzerland	
August	19. -20.	GP	Great Britain	Brooklands	
September	2. - 3.	GP	Germany	Munster	
October	7. -8.	GP	Spain	Alcobendas (Madrid)	
March	25. - 26.	International LS OR	Spain	Salou	
May	13.-14.	International LS OR	France	Paris/ Lille	
		International LS OR	Great Britain		
August	5.-6.	International LS OR	Belgium	Luik	

## 7 ALLOCATIONS

Allocations were made to each country as printed in the table form under item 2 on the agenda.

## 8 RULE PROPOSALS

---

### CLEANING UP THE HANDBOOK

---

The Section Chairmen get the allowance (agreement) to look after the rules in Appendix 5 to make it more clear. The rules should be put into an order that is uniform for all IC classes, as much as possible. No rule should be completely removed.

Proposed by: EFRA Executive Committee

Seconded by: Sweden

Not Seconded

Against : 1 Abstention: In favour: 12

**Remark:** Every year a lot of rules are amended, new or deleted. That creates sometimes irritations. Also this year we have to remove (delete) something from the Appendix, that is there twice. It also would help drivers, officials to find the relevant rules, if they are more uniformed (at the same number) in the handbook.

---

**THE RULE SHOULD BE AMENDED TO READ (highlighted sentence to be deleted)**

**8.2.6**

8.2.6 Tyres

Rim Diameter max.:107mm  
Rim and fitted tyre Diameter max.:136mm  
Rim and fitted tyre width - front max.:75mm  
Rim and fitted tyre width – rear max.:80mm

Tyres have to black and only semi pneumatic rubber. The design of the tyre Profile is free. Foam tyres are not allowed.

**The chemical treatment of tyres by adding any tyre traction moistures or other Chemical/additives is not allowed. Tyre cleaners are not allowed**

**Proposed by: BRCA**

**Seconded by: Germany**

**Not Seconded**

Against : - Abstention: - In favour: unanimous

Amendment: by France

It is not allowed to treat the tyres in the pit area:

**Seconded by: Belgium**

**Not Seconded**

Against : 3 Abstention: 4 In favour: 8

Amendment by BRCA

It is recommended that the chemical components of the product must be harmless for people and environment. liability at the use of tyre additives lies at the user and manufacturer

**Seconded by: Belgium**

**Not Seconded**

Against : - Abstention: 1 In favour: 12

**Remark:** Tyre additives are virtually impossible to detect and are being used by some drivers already. To make future competitions fair and equal for all drivers the sentence banning tyre additives/treatments should be removed.

If a system of testing tyres has been found/purchased that is 100% accurate by the AGM, then this rule amendment should be withdrawn.

---

**THE RULE SHOULD BE AMENDED TO READ**

**8.2.7 Engine and fuel**

**old**

Paragraph 6. Only open deck admission ports are allowed. ~~The sidewalls must be parallel without any change of the distance.~~

It had to be/the new wording:

Paragraph 6: Only open deck admission ports are allowed. The removing of materiel is free as long as the open deck shape of the ports in the direction of the piston is secured.

**Proposed by: EFRA Executive Committee**

**Seconded by:**

**Not Seconded**

Against : Abstention: In favour:

**Remark:** All the new type Zenoah engines ZG230 RC (and ZG260 RC) are out of the rules. This clarification was done in Bologna at March 12<sup>th</sup> 2005 by the LS Chairman

**Withdrawn**

---

**THE RULE SHOULD BE AMENDED TO READ**

**8.2.7.6**

6. Only open deck admission ports are allowed, **The removal of material is free as long as the modified shape of the transfer/admission port walls are in the direction of the cylinder bore at all times.**

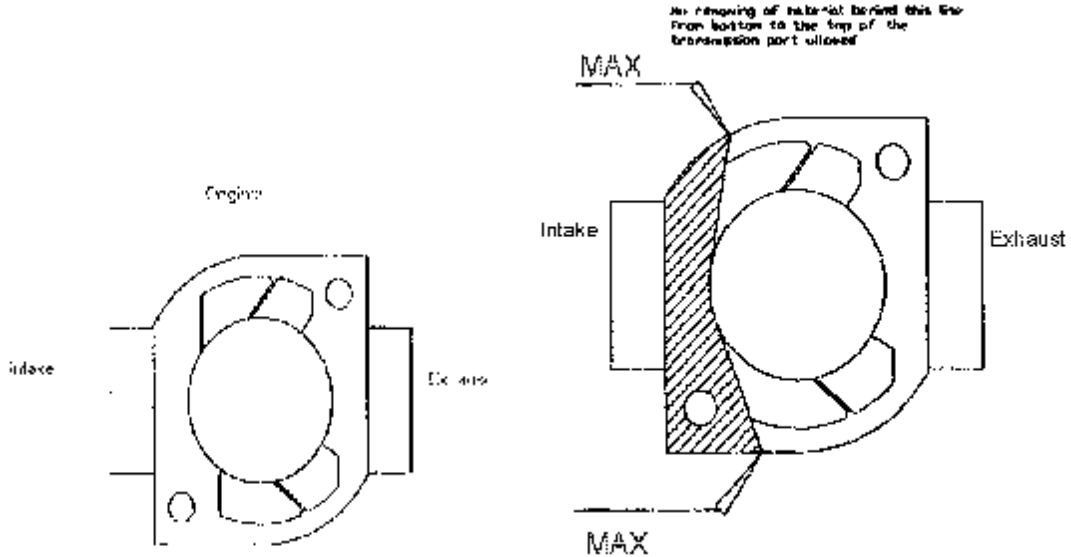

Proposed by: SRCCA  
 Seconded by: BRCA

Not Seconded

Against : - Abstention:- In favour: unanimous

Remark: This rule was used at the IFMAR WC in Lostalio. All checked engines complied with this rule.

**THE RULE SHOULD BE AMENDED TO READ**

**Engine and Fuel 8.2.7.1 and 5, app. 5**

1. Only **two** marked **engines to** be allowed. The race director may decide an engine replacement.....
5. To be deleted.

Proposed by: SBF Sweden  
 Seconded by:

Not Seconded

Against : Abstention: In favour:

Remark: The engines have become less and less expensive. The penalty for changing engines, regardless of what reason, is not reasonable. Further more, in case of rain it will be easier for the driver to meet the changed race situation.

Item 5 is not valid due to what it is said in 7.3 that ..... "any other electronic systems are not allowed". That should be due regardless of power source

withdrawn

**THE RULE SHOULD BE AMENDED TO READ**

**8.2.7 ENGINE and FUEL**

**8.2.7.1 Only two marked engines allowed. If it looks like for a longer rain period it will possible to use an third engine for this wet races, who will be marked as an WET ENGINE.**

Proposed by: RCA Czech Republic  
 Seconded by: NOMAC Holland

Not Seconded

Against : 10                      Abstention:                      In favour: 3                      failed  
Remark:

---

**THE RULE SHOULD BE AMENDED TO READ**

**7.7**

The following shall be deleted.

... the engine cut out ... use in 1:5

Proposed by: SBF Sweden

Seconded by:

Not Seconded

Against :                      Abstention:                      In favour: \_\_\_\_\_

Remark: The rule 7.7.6 says that it shall follow the 1:5 scale rules.

---

**THE RULE SHOULD BE AMENDED TO READ**

**7.7.7**

The rule is moved to 2.1.1 The rule is amended to:

.... Qualification Heats: 6 heats 10 minutes. Fastest **5 laps counts. The laps shall be together.** Rolling start

Proposed by: SBF Sweden

Seconded by: BRCA

Not Seconded

Against :                      Abstention:                      In favour: \_\_\_\_\_

Remark: Today you drive 60 minutes to get **one fast lap**. It is to easy. And a penalty is of no use .  
**withdrawn**

---

**THE PROPOSED RULE IS NEW**

**Technical rules 1:6<sup>th</sup> off road**

## **Large Scale Off - Road Rules**

1.) **Bodies and Wing.** The bodies must be such like used in Off Road, Desert and Trial events. It is allowed to use a wing in the following dimensions

- a.) wing body                      max 300 mm x 140 mm
- b.) height                      max 360 mm suspension fully compressed
- c.) Overhang                      max 150 mm from the centre of the rear axle

2.) **Safety.** Cars with open chain drives and gears, to have a protector . There must be a front plastic bumper fitted to the car.

3.) **Dimensions.**

- a.) length                      max. 820 mm
- b.) width                      max. 480 mm suspension fully compressed
- c.) height                      max. 360 mm suspension fully compressed
- d.) weight                      min 8000 Gramm (8 Kilos)
- e.) Fuel tank size                      max 700 ccm

4.) **Engines.** 1 Zylinder/2 stroke engine up to 26 ccm with similar engine rules as 1/5 on road IC track, regarding liners, cooling, transmission ports, ignition, and the ban of rotary valve and wankel engines.

5.) **Chassis and Transmission.** Only 2 RWD allowed.. 2 speed drive is banned.

6.) **Noise.** The engine had to be equipped in minimum with a 2 chamber pipe who don't exceed the level of 81 DbA measured in 10 meters, 1 meter over the ground. This pipe had to be inside the max dimensions of the car.

7.) **Fuel.** To follow 3.2  
as possible

7.) **Brakes.** A car must have brakes to be stopped.  
A mechanical failsafe at the carburettor is mandatory. (Spring at the throttle valve)

8.) **Race Format.**  
To be followed Appendix 2.

**Proposed by: EFRA Executive Committee**  
**Seconded by: Germany**

**Not Seconded**

Against : - Abstention: \_\_\_\_\_ In favour: unanimous

**Remark:** The draft was already discussed during the AGM in Dubrovnik but withdrawn due to lack of interest. It now seems, that we need these rules.

---

**THE RULE SHOULD BE AMENDED TO READ**  
**7.7.2**

The following shall be deleted

**Only one engine... .. till the end of the event.**

**Proposed by: SBF Sweden**  
**Seconded by:**

**Not Seconded**

Against : \_\_\_\_\_ Abstention: \_\_\_\_\_ In favour: \_\_\_\_\_

**Remark:** Stays in rule number 7.7.3

**withdrawn**

---

**THE PROPOSED RULE IS NEW**  
**8.2.6.2**

Tyres.

Only 2 sets ( 8 tyres) of tyres of any fabricate is allowed during the qualification section of a race and should be registrated at technical inspection before the qualification rounds starts. An additional 1 set of tyres (4 tyres) could be registrated before the Final starts.

For EC; following tyre rule is due.

1.1 Producer: EFRA AGM nominates each year two producers to be allowed to supply tires glued on rims to the EC organisers.

1.2 One month before the EC, the nominated producers send to the respective organiser marked and glued tires of different hardness and mix.

1.3 The tires should be held in consignment stock by the producer but sold to the drivers by the organiser to an, between the EFRA/producer/organiser, agreed price.

1.4 EFRA and/or the organiser mark the tires with own marking.

1.5 Receipt must be given to all drivers to make it possible to get the money refunded by sponsor's etc.

1.6 After EC the remaining stock of tires will be sent back to the producer.

**Proposed by: SBF Sweden**  
**Seconded by:**

**Not Seconded**

Against : \_\_\_\_\_ Abstention: \_\_\_\_\_ In favour: \_\_\_\_\_

**Remark:** To develop equal presumptions for all drivers and keep the increasing cost down

withdrawn

---

**THE RULE SHOULD BE AMENDED TO READ**

**Race Format 1.**

The whole paragraph as it is written now should be deleted and swooped against a new one as per below:

**1. Race Format**

**1.1 The European Championship to determine the European Champion will each year be held as a series of 5 Grand Prix races +1 Final. Out of those 6 races the Final and the 3 best GP's will be counted and nominate the European Champion.**

**1.2 The result of the series will give the EFRA ranking list.**

**1.3 The same format is used both for:**

**a) 1:4 Scale GT/salon, Formula 1**

**b) 1:5 Scale Touring cars**

**all classes could be combined in one race during 4 days Thursday to Sunday if number of participants are below 80 . If above 80 the race should be held during 5 days, Wednesday to Sunday.**

**1.4 Participants must have an EFRA International Drivers Licence to be allowed to participate in the series of GP's and Final held outside their own country.**

**1.5 Entry and sanction fees as written in General rules 3.5.7**

**Proposed by: SBF Sweden**

**Seconded by: Belgium**

**Not Seconded**

Against : \_\_\_\_\_ Abstention: \_\_\_\_\_ In favour: \_\_\_\_\_

**Remark:** The GP's to day seems to have lost rather much of it's status and it is time to renew the model in order to keep up the activities. The number of drivers seems also to have dropped during the past year. The new model will increase the interest and increase the racing activities

withdrawn

---

**THE RULE SHOULD BE AMENDED TO READ**

**Race procedure 2.1**

Duration of the races:

Free practice .....

Heats: ..... **Definition of the word "heats": Heat is only related to the qualification rounds and the length should be 10 minutes (plus the last lap and time of the last lap)**

Sub-finals: **Up to and including the 1/64 finals the length should be 15 minutes. As from 1/32 final up to The final the length should be 20 minutes ( last lap and time of last lap always included)**

Final: **60 minutes including one fuelling (plus last lap and time of last lap). No time break for fuelling. However during fuelling the engine has to be switched of and fuelling done in a separate fuelling pit..**

**Proposed by: SBF Sweden**

**Seconded by: BRCA**

**Not Seconded**

Against : 6 \_\_\_\_\_ Abstention: 4 \_\_\_\_\_ In favour: 3 \_\_\_\_\_ failed

**Remark:** In order to make it clear how many tires to be used. As the writings are now it is unclear whether it will be allowed to use new tires for the Finals.

Regarding length of finals; The shorter sub finals up to and incl. 1/64 will make it a little bit easier for drivers that goes the long way to the final to get the car in mechanical shape longer.

60 minutes finals with fuelling makes the racing more similar to full scale racing where fuelling is mandatory.

---

**THE RULE SHOULD BE AMENDED TO READ**

**Race procedure 2.2**

- a) The EFRA Christmas Tree will be.....
- b) .....
- c) Top two qualifiers goes direct to Final**
- d) Sub-Finals:.....
- e) Semi-final The first **3** drivers from each semi-final.....
- f) In the event of different weather conditions during..... the first **four** drivers from each semi-final will.....

**Proposed by: SBF Sweden**

**Seconded by:**

**Not Seconded**

Against : \_\_\_\_\_ Abstention: \_\_\_\_\_ In favour: \_\_\_\_\_

**Remark:** It has to be some reward for the top qualifiers. It should have been only one, the TQ, direct qualified but such a solution will cause problem moving up driver from semi if the weather conditions are different.

**withdrawn**

---

**THE RULE SHOULD BE AMENDED TO READ**

**2.2 RACE PROCEDURE**

- 2.2 a) The EFRA Christmas Tree will be used.
- b) The Best 4 drivers of the heats will be qualify directly into the Final.**
- c) Semi-final : The first 2 drivers from each semi-final progress up to the final together with the next 2 drivers with the best times from the 2 semi-finals combined

**Proposed by: RCA Czech Republic**

**Seconded by: Germany**

**Not Seconded**

Against : 10 \_\_\_\_\_ Abstention: 1 \_\_\_\_\_ In favour: 2 \_\_\_\_\_

**Remark:**

---

**THE RULE SHOULD BE AMENDED TO READ**

**2.5**

Existing text to be deleted and replaced by the one below.  
- 12 **before 30 seconds is announced to start the mechanic is allowed to do s.c " fuel topping" of the car. Such fuel topping should be done with the car engine switched of and at a place separated from the rostrum. No other refuelling is allowed before heat starts.**

**Proposed by: SBF Sweden**

**Seconded by: Austria**

**Not Seconded**

Against : 9 \_\_\_\_\_ Abstention: 1 \_\_\_\_\_ In favour: 3 \_\_\_\_\_ failed

**Remark:** This amendment should secure a more fair racing and avoid drivers to run out of fuel due to different reasons during the warm up period.

---

**THE RULE SHOULD BE DELETED**

**4.**

Marshals are not allowed. mechanics will act as marshals out from the pit lane.

**Proposed by: BRCA Great Britain**

**Seconded by: Sweden**

**Not Seconded**

Against : \_\_\_\_\_ Abstention: \_\_\_\_\_ In favour: \_\_\_\_\_

**Remark:** This is very dangerous in several ways.  
**withdrawn**

Amendment made by Sweden: This rule can not overrule national insurance regulations.

**Seconded by: Norway**

**Not Seconded**

Against : - Abstention: - In favour: unanimous

- 1) It is very dangerous for the mechanic; they may have to cross several parts of the circuit with cars going in different directions at high speed.
- 2) It is very dangerous for the organisers of the meeting from a legal standpoint.
  - i) Model car racing is a recognised motorsport in many countries, we are insured as such, marshalling is recognised as being done from marshals posts about the track, if we have an accident with a mechanic and they are on the circuit (e.g. not in the pit lane) then anywhere that model car racing is recognised as a motorsport it will be at the race directors responsibility if the above rule remains.
  - ii) Where model car racing is not a sport, if following an accident legal action was to happen the concept of why a mechanic was required to run across a circuit will be very difficult for the organiser to defend. Most people have seen Marshals at the side of a race track on Television, when dealing with the general public it helps to operate in a manner which they can relate other activities to.

We must remember that EFRA rules do not supersede EEC or Country law and legal precedent, in most European countries the organisers of any event are responsible for the safety of those attending the event, RC car racing is no different. As organisers we accept this responsibility and must take all steps to minimise not only the risk to the individuals but also the risk to the activity.

The rules for marshals should be as general rules 8.15.x

As a minimum the above rule must be amended to reflect those countries where model car racing is part of the national motor sport association.

---

**THE RULE SHOULD BE AMENDED TO READ**  
**7.7.7 Special regulations (Formula 1)**

3 round of timed practice

Qualification heats:

6 heats 10 minutes Fastest **5 consecutive laps counts**. Rolling start

Lower Finals up to quarter final, 20 minutes

**Semifinale** 30 minutes

Final EC **45** minutes

**Proposed by: NRCBF Norway**

**Seconded by: Sweden**

**Not Seconded**

Against : 1 Abstention: - In favour: 12

**Remark:** Simplify by using wording semi finale as in the other appendixes.

To drive total 60 minutes qualification when only one – 1 - lap counts, is not racing ore friendly for the public. Racing RC-car is to show fast and even driving over time.

To change the time of racing in the final from 35 to 45 minutes, forces everyone to refill their fuel-tanks. Now its available fuel-tanks like in Track IC, who is making the refilling easy and fast. This will make more modifications of engines when using more fuel is no longer a problem. When changing the time for the final from 35 to 45 minutes will it became necessary for all drivers to refill and no difference between them.

**THE RULE SHOULD BE AMENDED TO READ**

**8.2.3**

**Ignition Kill Switch**

The ignition kill switch must be on his original place on the engine and the window on this side must be cut out. The position must be marked with an E (size 20mm) on the bodyshell. To create more safety, it is allowed to have a second kill switch fixed near the rear window to allow easy access. This kill switch should be away from hot or moving parts.

**Proposed by: EFRA Executive Committee**

**Seconded by: Germany**

**Not Seconded**

Against : - Abstention: - In favour: unanimous

**Remark:** To follow the IFMAR rules. As it can be seen during the meeting by some documentation, all IC operated tools have the kill switch on an easy to touch position. At nearly no tool that kill switch is located at the engine. All the discussion about CE is only a fake, the drivers only want to avoid extra work when they change an engine. They don't care about CE for fixing extra gadgets at the kill switch if they think that will give them an advantage.

**9 ELECTION OF SECTION CHAIRMAN.**

*Wolfgang Stumpf was elected unanimous*

*Wolfgang Petermann was elected unanimous*

**10 ANY OTHER BUSINESS,**

Zagreb is planning a new track, that will be finished around 2007

**11 ITEMS FOR GENERAL DISCUSSION.**

**NRCBF Norway**

At the EC Formula 1 in Sweden, the drivers had to move the stop-button from the original place on the engine to back on the car. The rule is clear at this point and says the button must be on the original place on the engine. We hope this will be clear at the next EC and the drivers not have to do this again next time.

At the same EC: Technical inspections find the fuel from two drivers to not be legal fuel. The inspector decided "not to do anything, because they where not the best drivers". This should not happen again. When the Team-managers were told this at a team-manager meeting, it was too late to protest. In such cases the inspector must act and report to race director. The race director will then give the penalty. It must not be up to the inspector to decide who will be allowed to not following the rules. This is also one of many things when it became to technical rules, only driver, the drivers team-manager and inspector can find/know about it, and therefore impossible for other drivers to protest against it, if its not published before the time for protesting is running out. When we also have a very clear rule about using illegal fuel, appendix 5 § 3.2, there should not be any questions about what to do if illegal fuel is found in any cars.

After this incident, we hope inspectors will follow the rules and not take their own decisions about who shall be reported for not follow the technical rules to the race director. Other drivers have to trust this will be done in every case, to make fear competitions.

**The meeting was closed at : 18:49**